

WENTYLACJA CHEMOODPORNĄ
Z TWORZYW SZTUCZNYCH

CHEMOWENT[®]

KATALOG TECHNICZNY

KANAŁY I KSZTAŁTKI

O PRZEKROJU OKRĄGLYM I PROSTOKĄTNYM

SPIS TREŚCI

1. Kanaly i kształtki okrągłe

1.1a Kanał okrągły Ø32 - Ø600 mm	9
1.1b. Kanał okrągły z płyt Ø450 - Ø1400 mm	10
1.2. Rura elastyczna z PVC, z wewnętrzną spiralą drucianą do stabilizacji	11
1.3. Kolano okrągłe - łuk 90°/75°/60°/45°/30°/15° 160.....	12
1.4. Trójnik okrągły 90°	14
1.5. Trójnik okrągły 45°	15
1.6 Trójnik okrągły redukcyjny 90°	16
1.7. Trójnik okrągły redukcyjny 45°	19
1.8. Trójnik okrągły orłowy 90°	22
1.9. Trójnik okrągły orłowy 45°	23
1.10. Mufa okrągła	24
1.11 Redukcja okrągła	25
1.12. Kołnierz mufowy.....	29
1.13. Kołnierz luźny.....	30
1.14. Kołnierz ślepy.....	31
1.15. Uszczelka EPDM do kołnierzy	32
1.16. Przepustnica regulacyjna ręczna mufowa	33
1.17. Przepustnica regulacyjna ręczna kołnierzowa	35
1.18. Przepustnica regulacyjna pod napęd elektryczny, mufowa	37
1.19. Przepustnica regulacyjna pod napęd elektryczny, kołnierzowa	39
1.20. Przepustnica regulacyjna z napędem pneumatycznym, mufowa	41
1.21. Przepustnica regulacyjna z napędem pneumatycznym, kołnierzowa	42
1.22. Kłapa zwrotna do zabudowy pionowej - model 1	43
1.23. Kłapa zwrotna do zabudowy pionowej - model 2.....	44
1.24. Kłapa zwrotna do zabudowy poziomej - model 3.....	45
1.25. Króciec z siatką ochronną.....	46
1.26. Przejście dachowe z tworzywa - nachylenie 0°	47
1.27. Przejście dachowe z tworzywa - nachylenie 1-22°	48
1.28. Przejście dachowe z tworzywa - nachylenie 23-45°	49
1.29. Osłona przeciwdeszczowa.....	51
1.30. Wyrzutnia dachowa - deflektor.....	52
1.31. Wywietrzak dachowy cylindryczny	54
1.32. Podstawa dachowa pod wentylator	55
1.33. Zaślepka z tworzywa.....	56
1.34. Kratka z regulowanymi lamelami PVC.....	57
1.35. Trójnik rewizyjny.....	58
1.36. Króciec rewizyjny	59
1.37. Przejście ściennie	60
1.38. Złącze elastyczne 4 karbowe PVC i TPE, łączenie na opaski	61
1.39. Złącze elastyczne 4 karbowe PVC i TPE, łączenie na mufy.....	62
1.40. Złącze elastyczne 4 karbowe PVC i TPE, łączenie na kołnierze	63
1.41. Złącze elastyczne 6 karbowe TPE, łączenie na opaski	64
1.42. Złącze elastyczne 6 karbowe TPE, łączenie na mufy	65
1.43. Złącze elastyczne 6 karbowe TPE, łączenie na kołnierze	66
1.44. Kratka.....	67
1.45. Ramka montażowa do kratki.....	68
1.46. Króciec siodłowy 90°	69
1.47. Króciec siodłowy 45°	70
1.48. Tłumik okrągły	71

2. Kanały i kształtki prostokątne

2.1 Kanał prostokątny	77
2.1 Kolano/ łuk prostokątny.....	77
2.3 Trójkąt prostokątny	78
2.4 Redukcja symetryczna	78
2.5 Redukcja asymetryczna	79
2.6 Redukcja/przejście kwadrat - koło	79
2.7 Odsadzka prostokątna	80
2.8 Przepustnica prostokątna	80
2.9 Czerpnia ścienna	81
2.10 Czerpnia / wyrzutnia dachowa	81
2.11 Podstawa dachowa	82
2.12 Kratka.....	82
2.13 Tłumik prostokątny	83

Kanały i kształtki okrągłe



Wymiary kształtek i kanałów okrągłych

Wielkość nominalna będąca wymiarem umownym do oznaczania i obliczeń przewodów prostych i kształtek, stanowi **zewnętrzny** wymiar – **D**.

Szczelność

Przy połączeniach kanałów i kształtek poprzez spawanie szczelność systemu wynosi 100%.

Sztywność

Kanały i kształtki są usztywniane poprzez odpowiednio dobraną grubość materiału, z którego są wykonane.

W przypadku dużych średnic możliwe jest zastosowanie ożebrowania wzmacniającego w celu ograniczenia grubości płyty.

Metody łączenia

Możliwe metody łączenia okrągłego systemu kanałów i kształtek:

- Spawanie drutem
- Klejenie (tylko tworzywo PVC do średnicy 250mm)
- Łączenie na kołnierze

Materiały do produkcji i symbole oznaczeń

- **PVC** – kolor ciemny szary - 88
- **PP-EL-s** – kolor czarny - 40
- **PPs** – kolor szary - 36
- **PP** – kolor jasny szary - 30
- **PE** – kolor czarny - 22

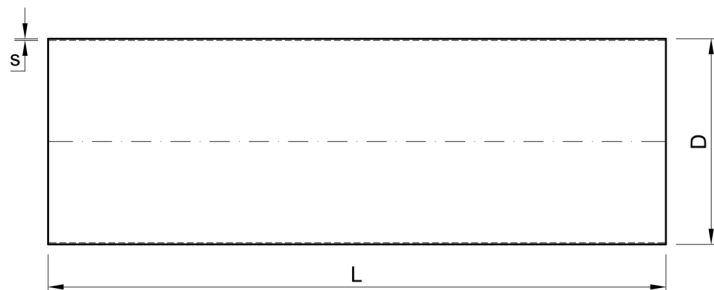
1.1a Kanał okrągły Ø32 - Ø600 mm

D	Nr kat.	L	PVC		PPs	PP-EL-s	PP	PE
			s	s1				
mm	---	mm	mm		mm			
32	XX.032.Y.0000	2500 / 5000	1,9	-	3,0	3,0	2,9	1,9
40	XX.040.Y.0000	2500 / 5000	1,9	-	3,0	3,0	3,7	2,3
50	XX.050.Y.0000	2500 / 5000	1,8	-	3,0	3,0	4,6	2,9
63	XX.063.Y.0000	2500 / 5000	1,9	-	3,0	3,0	5,8	3,6
75	XX.075.Y.0000	2500 / 5000	1,8	-	3,0	3,0	1,9	4,3
90	XX.090.Y.0000	2500 / 5000	1,8	-	3,0	3,0	2,2	5,4
110	XX.110.Y.0000	2500 / 5000	1,8	-	3,0	3,0	2,7	2,7
125	XX.125.Y.0000	2500 / 5000	1,8	-	3,0	3,0	3,1	3,1
140	XX.140.Y.0000	2500 / 5000	1,8	-	3,0	3,0	3,5	3,5
160	XX.160.Y.0000	2500 / 5000	1,8	2,5	3,0	3,0	4,0	4,0
180	XX.180.Y.0000	2500 / 5000	1,8	2,5	3,0	-	4,4	4,4
200	XX.200.Y.0000	2500 / 5000	1,8	2,5	3,0	3,0	4,9	4,9
225	XX.225.Y.0000	2500 / 5000	1,8	2,8	3,5	3,5	5,5	5,5
250	XX.250.Y.0000	2500 / 5000	2,0	2,9	3,5	3,5	3,5	6,2
280	XX.280.Y.0000	2500 / 5000	2,3	2,9	4,0	-	6,9	6,9
315	XX.315.Y.0000	2500 / 5000	2,5	2,9	5,0	5,0	5,0	7,7
355	XX.355.Y.0000	2500 / 5000	2,9	4,4	5,0	-	5,0	8,7
400	XX.400.Y.0000	2500 / 5000	3,2	5,0	6,0	6,0	6,0	9,8
450	XX.450.Y.0000	2500 / 5000	3,6	5,6	7,0	-	7,0	11,0
500	XX.500.Y.0000	2500 / 5000	4,0	5,6	8,0	8,0	8,0	12,3
600*	88.600.L.0000	2500 / 5000	5,0	-	-	-	-	-

* rura Ø 600 mm w tym wariantcie wykonania tylko z tworzywa PVC

1.1b. Kanał okrągły z płyt Ø450 - Ø1400 mm

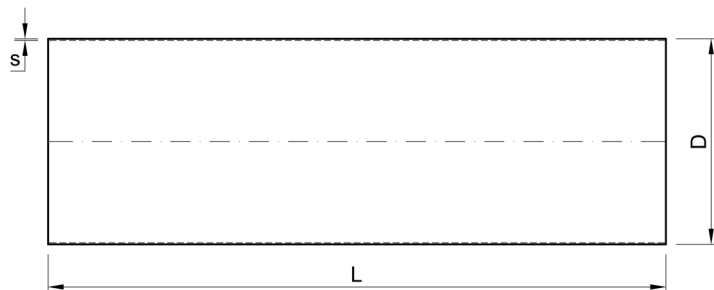

D	Nr kat.	L	s	s1
mm	---	mm	mm	
450	XX.450.Y.0000	500 / 1000 / 1500 / 2000	4,0	-
500	XX.500.Y.0000	500 / 1000 / 1500 / 2000	4,0	6,0
560	XX.560.Y.0000	500 / 1000 / 1500 / 2000	4,0	6,0
600	XX.600.Y.0000	500 / 1000 / 1500 / 2000	6,0	8,0
630	XX.630.Y.0000	500 / 1000 / 1500 / 2000	6,0	8,0
700	XX.700.Y.0000	500 / 1000 / 1500 / 2000	6,0	8,0
710	XX.710.Y.0000	500 / 1000 / 1500 / 2000	6,0	8,0
800	XX.800.Y.0000	500 / 1000 / 1500 / 2000	8,0	10,0
900	XX.900.Y.0000	500 / 1000 / 1500 / 2000	8,0	10,0
1000	XX.1000.Y.0000	500 / 1000 / 1500 / 2000	10,0	12,0
1250	XX.1250.Y.0000	500 / 1000 / 1500 / 2000	12,0	15,0
1400	XX.1400.Y.0000	500 / 1000 / 1500 / 2000	12,0	15,0

Oznaczenia w tabelach:

- D** - średnica zewnętrzna kanału
- L** - długość kanału
- Y** - grubość ścianki (**s**—ścianki standard, **s1**—ścianka pogrubiona)
- XX** - oznaczenie materiału w systemie Chemowent

1.2. Rura elastyczna z PVC, z wewnętrzną spiralą drucianą do stabilizacji

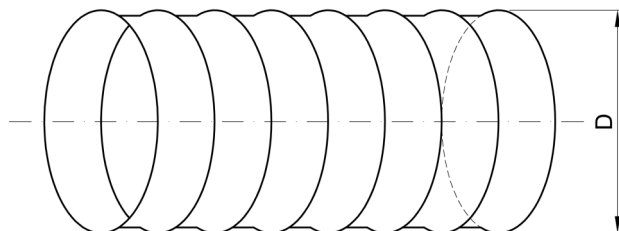

D	Nr kat.	Waga	Promień gięcia	Ciśnienie robocze	Podciśnienie
mm	---	kg/m	---	max bar	bar
50	88.050.RF.0000	0,24	35,00	0,35	0,15
63	88.063.RF.0000	0,29	42,00	0,35	0,14
75	88.075.RF.0000	0,34	49,00	0,30	0,12
90	88.090.RF.0000	0,36	53,00	0,30	0,10
110	88.110.RF.0000	0,39	56,00	0,25	0,09
125	88.125.RF.0000	0,50	70,00	0,20	0,08
140	88.140.RF.0000	0,60	85,00	0,20	0,07
160	88.160.RF.0000	0,62	88,00	0,15	0,06
180	88.180.RF.0000	0,70	95,00	0,10	0,06
200	88.200.RF.0000	0,73	105,00	0,08	0,05
225	88.225.RF.0000	0,81	123,00	0,06	0,04
250	88.250.RF.0000	0,99	140,00	0,05	0,03
280	88.280.RF.0000	1,23	175,00	0,04	0,03
315	88.315.RF.0000	1,49	210,00	0,03	0,02
355	88.355.RF.0000	1,98	245,00	0,02	0,02
400	88.400.RF.0000	2,26	280,00	0,02	0,01
450	88.450.RF.0000	2,54	315,00	0,01	0,01
500	88.500.RF.0000	2,83	350,00	0,01	0,01

Oznaczenia w tabeli

- D** - średnica wewnętrzna rury
- 88** - oznaczenie materiału PVC w systemie Chemowent

Maksymalna długość w jednym odcinku - 10 m

Minimalna długość handlowa - 1 m

Metody łączenia - opaski zaciskowe

1.3. Kolano okrągłe - łuk 90°/75°/60°/45°/30°/15°/160

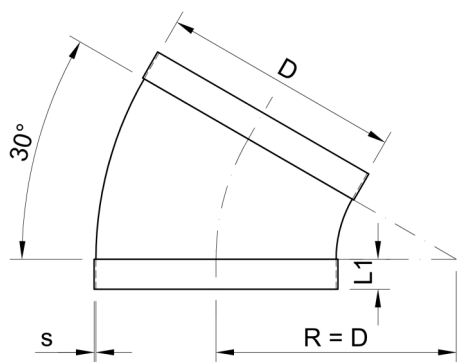
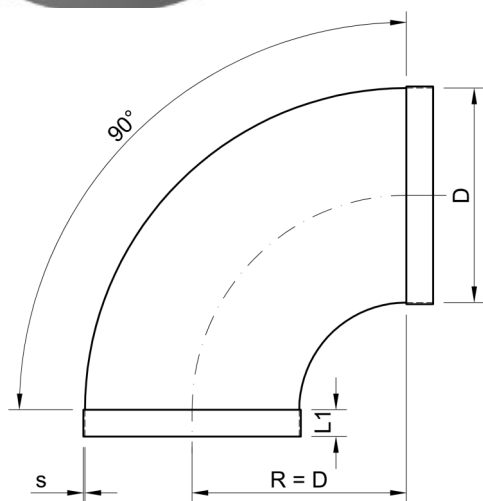
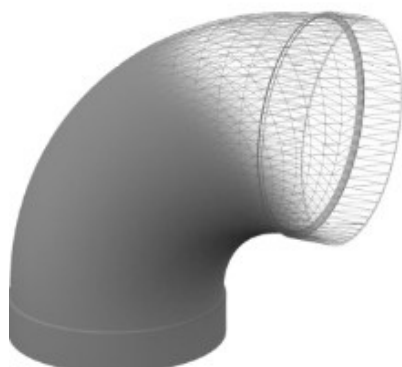

Oznaczenia w tabeli:

- a. **D** - średnica zewnętrzna rury
- b. **s** - grubość ścianki
- c. **L1** - długość mufy
- d. **XX** - oznaczenie materiału w systemie Chemowent
- e. **YY** - oznaczenie kąta - 90°, 75°, 60°, 45°, 30°, 15°

D	Nr kat.	PVC		PPs/PP-EL-s/PP/PE	
		L1	s	L1	s
mm	---	mm	mm	mm	mm
50	XX.050.L.00YY	25	1,8	25	3,0
63	XX.063.L.00YY	25	1,8	25	3,0
75	XX.075.L.00YY	40	1,8	40	3,0
90	XX.090.L.00YY	40	1,8	40	3,0
110	XX.110.L.00YY	40	1,8	40	3,0
125	XX.125.L.00YY	40	1,8	40	3,0
140	XX.140.L.00YY	40	1,8	40	3,0
160	XX.160.L.00YY	40	1,8	40	3,0
180	XX.180.L.00YY	40	1,8	40	3,0
200	XX.200.L.00YY	40	1,8	40	3,0
225	XX.225.L.00YY	40	1,8	40	3,5
250	XX.250.L.00YY	40	2,0	40	3,5
280	XX.280.L.00YY	50	2,3	50	3,5
315	XX.315.L.00YY	50	4,9	50	4,0
355	XX.355.L.00YY	50	2,9	50	4,0
400	XX.400.L.00YY	50	3,2	50	4,5
450	XX.450.L.00YY	50	3,6	50	5,0
500	XX.500.L.00YY	50	4,0	50	5,0
560	XX.560.L.00YY	-	-	60	4,0
600	XX.600.L.00YY	60	5,0	60	6,0
630	XX.630.L.00YY	-	-	70	6,0
700	XX.700.L.00YY	-	-	70	6,0
710	XX.710.L.00YY	-	-	80	6,0
800	XX.800.L.00YY	-	-	80	8,0
900	XX.900.L.00YY	-	-	90	8,0
1000	XX.1000.L.00YY	-	-	100	10,0
1200	XX.1200.L.00YY	-	-	120	12,0
1250	XX.1250.L.00YY	-	-	130	12,0

Współczynnik oporów miejscowych [ζ]:

kolano/tuk 90° - 0,25

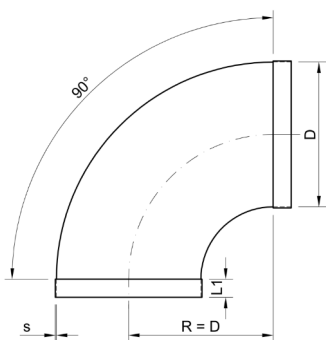

kolano/tuk 75° - 0,20

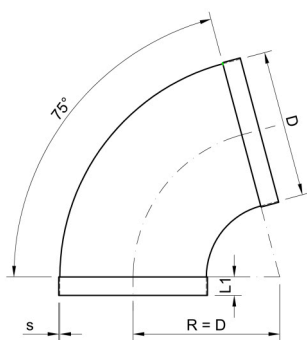

kolano/tuk 60° - 0,18

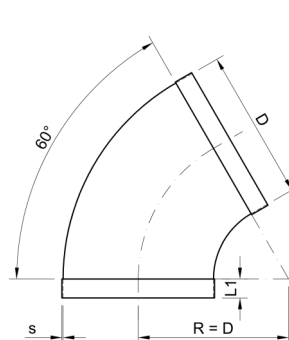

kolano/tuk 45° - 0,15

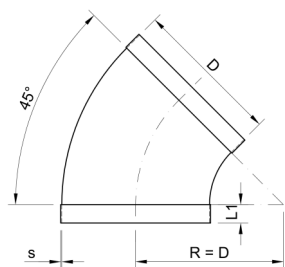

kolano/tuk 30° - 0,10

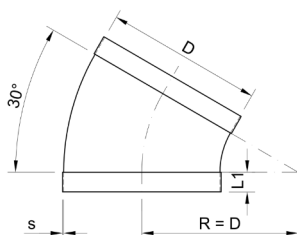

kolano/tuk 15° - 0,05

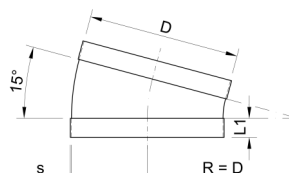

1.4. Trójnik okrągły 90°

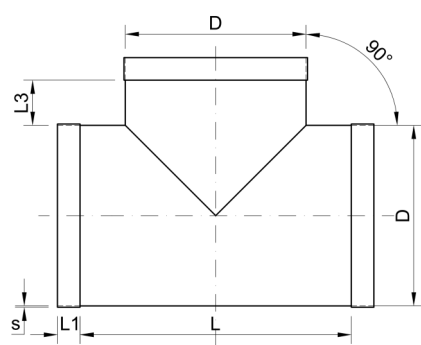
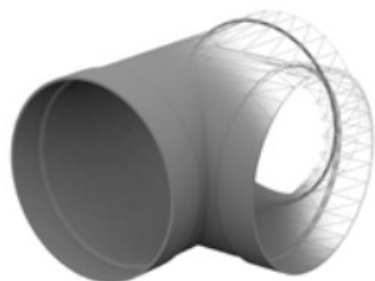

D	Nr kat.	L1	L	L3	PVC	PPs/PP-EL-s/ PP/PE
					s	
mm	---	mm	mm	mm	mm	mm
50	XX.050.L.9000	25	75	12	2,50	3,00
63	XX.063.L.9000	25	75	6	2,50	3,00
75	XX.075.L.9000	40	105	15	2,50	3,00
90	XX.090.L.9000	40	120	15	2,50	3,00
110	XX.110.L.9000	40	140	15	2,50	3,00
125	XX.125.L.9000	40	155	15	2,50	3,00
140	XX.140.L.9000	40	170	15	2,50	3,00
160	XX.160.L.9000	40	190	15	2,50	3,00
180	XX.180.L.9000	40	210	15	2,50	3,00
200	XX.200.L.9000	40	230	15	2,50	4,00
225	XX.225.L.9000	40	270	15	2,50	4,00
250	XX.250.L.9000	40	280	12	2,50	4,00
280	XX.280.L.9000	50	320	20	2,50	4,00
315	XX.315.L.9000	50	345	8	4,00	5,00
355	XX.355.L.9000	50	405	55	3,00	5,00
400	XX.400.L.9000	50	460	60	3,00	6,00
450	XX.450.L.9000	50	586	70	3,60	5,00
500	XX.500.L.9000	50	650	75	5,00	5,00
560	XX.560.L.9000	60	728	85	-	6,00
600	XX.600.L.9000	60	780	90	5,00	6,00
630	XX.630.L.9000	70	820	100	-	6,00
700	XX.700.L.9000	70	910	105	6,00	6,00
710	XX.710.L.9000	80	924	110	-	6,00
800	XX.800.L.9000	80	1040	120	8,00	8,00
900	XX.900.L.9000	90	1170	135	8,00	8,00
1000	XX.1000.L.9000	100	1300	150	10,00	10,00
1200	XX.1200.L.9000	120	1560	180	12,00	12,00
1250	XX.1250.L.9000	130	1626	190	12,00	12,00

Oznaczenia w tabeli:

- a. **D** - średnica zewnętrzna rury
- b. **s** - grubość ścianki
- c. **L1** - długość mufy
- d. **L** - długość trójnika
- e. **L3** - długość odejścia
- f. **XX** - oznaczenie materiału w systemie Chemowent

Współczynnik oporów miejscowych [ζ]: 1,10

1.5. Trójnik okrągły 45°

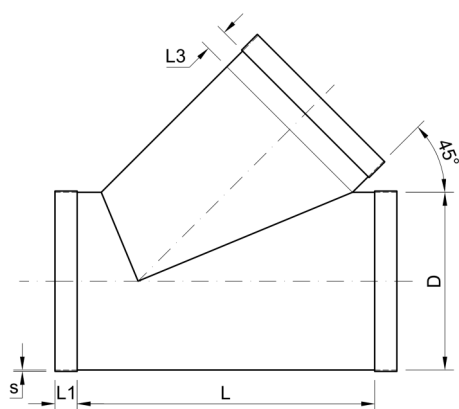

D	Nr kat.	L1	L	L3	PVC	PPs/PP-EL-s/ PP/PE
					s	
mm	---	mm	mm	mm	mm	mm
50	XX.050.L.4500	35	171	50	2,50	3,00
63	XX.063.L.4500	35	189	50	2,50	3,00
75	XX.075.L.4500	40	242	50	2,50	3,00
90	XX.090.L.4500	40	263	50	2,50	3,00
110	XX.110.L.4500	40	282	50	2,50	3,00
125	XX.125.L.4500	40	313	50	2,50	3,00
140	XX.140.L.4500	40	334	50	2,50	3,00
160	XX.160.L.4500	40	352	50	2,50	3,00
180	XX.180.L.4500	40	391	50	2,50	3,00
200	XX.200.L.4500	40	409	50	2,50	4,00
225	XX.225.L.4500	40	454	50	2,50	4,00
250	XX.250.L.4500	40	480	50	2,50	4,00
280	XX.280.L.4500	50	532	50	2,50	4,00
315	XX.315.L.4500	50	581	50	4,00	5,00
355	XX.355.L.4500	50	638	50	3,00	5,00
400	XX.400.L.4500	50	702	50	3,00	6,00
450	XX.450.L.4500	50	818	90	3,60	5,00
500	XX.500.L.4500	50	908	100	5,00	5,00
560*	XX.560.L.4500	60	1016	112	-	6,00
600	XX.600.L.4500	60	1090	120	5,00	6,00
630*	XX.630.L.4500	70	1144	126	-	6,00
700	XX.700.L.4500	70	1270	140	6,00	6,00
710*	XX.710.L.4500	80	1290	142	-	6,00
800	XX.800.L.4500	80	1452	160	8,00	8,00
900	XX.900.L.4500	90	1634	180	8,00	8,00
1000	XX.1000.L.4500	100	1816	200	10,00	10,00
1200	XX.1200.L.4500	120	2178	240	12,00	12,00
1250	XX.1250.L.4500	130	2268	250	12,00	12,00

Oznaczenia w tabeli:

- a. **D** - średnica zewnętrzna rury
- b. **s** - grubość ścianki
- c. **L1** - długość mufy
- d. **L** - długość trójnika
- e. **L3** - długość odejścia
- f. **XX** - oznaczenie materiału w systemie Chemowent

* w tych średnicach nie są produkowane trójniki z tworzywa PVC

Współczynnik oporów miejscowych [ζ]: 0,9

1.6 Trójnik okrągły redukcyjny 90°

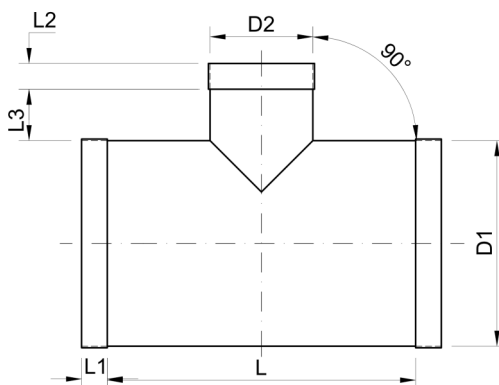
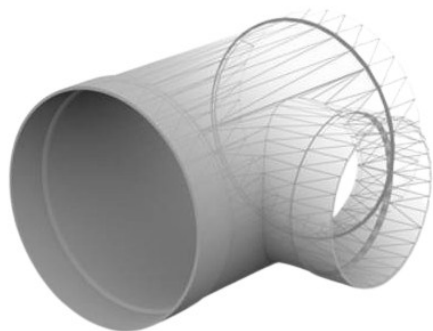

D1	D2	Nr kat.	PVC					PPs/PP-EL-s/ PP/PE				
			L	L1	L2	L3	s	L	L1	L2	L3	s
mm	mm	---	mm					mm				
63	50	XX.063.T.9050	150	25	25	50	2,5	150	25	25	50	3,0
75	50	XX.075.T.9050	150	40	40	50	2,5	150	40	40	50	3,0
75	63	XX.075.T.0063	160	40	40	50	2,5	160	40	40	50	3,0
90	50	XX.090.T.9050	150	40	40	50	2,5	150	40	40	50	3,0
90	63	XX.090.T.9063	160	40	40	50	2,5	160	40	40	50	3,0
90	75	XX.110.T.9063	175	40	40	50	2,5	175	40	40	50	3,0
110	63	XX.110.T.9075	160	40	40	50	2,5	160	40	40	50	3,0
110	90	XX.110.T.9090	190	40	40	50	2,5	190	40	40	50	3,0
125	50	XX.125.T.9050	150	40	40	50	2,5	150	40	40	50	3,0
125	75	XX.125.T.9075	175	40	40	50	2,5	175	40	40	50	3,0
125	110	XX.125.T.9110	210	40	40	50	2,5	210	40	40	50	3,0
140	90	XX.140.T.9090	190	40	40	50	2,5	190	40	40	50	3,0
140	110	XX.140.T.9110	210	40	40	50	2,5	210	40	40	50	3,0
160	50	XX.160.T.9050	150	40	40	50	2,5	150	40	40	50	3,0
160	110	XX.160.T.9110	210	40	40	50	2,5	210	40	40	50	3,0
160	125	XX.160.T.9125	225	40	40	50	2,5	225	40	40	50	3,0
180	90	XX.180.T.9090	190	50	40	50	2,5	190	50	40	50	3,0
180	110	XX.180.T.9110	210	50	40	50	2,5	210	50	40	50	3,0
180	160	XX.180.T.9160	260	40	40	50	2,5	260	40	40	50	3,0
200	110	XX.200.T.9110	210	40	40	50	2,5	210	40	40	50	4,0
200	125	XX.200.T.9125	225	40	40	50	2,5	225	40	40	50	4,0
200	160	XX.200.T.9160	260	40	40	50	2,5	260	40	40	50	4,0
200	180	XX.200.T.9180	280	40	40	50	2,5	280	40	40	50	4,0
225	110	XX.225.T.9110	210	40	40	50	2,5	210	40	40	50	3,5
225	125	XX.225.T.9125	225	40	40	50	2,5	225	40	40	50	3,5
225	160	XX.225.T.9160	260	40	40	50	2,5	260	40	40	50	3,5
225	200	XX.225.T.9200	300	40	40	50	2,5	300	40	40	50	3,5

D1	D2	Nr kat.	PVC					PPs/PP-EL-s/ PP/PE				
			L	L1	L2	L3	s	L	L1	L2	L3	s
mm	mm	---	mm					mm				
250	110	XX.250.T.9110	210	40	40	50	2,5	210	40	40	50	3,5
250	160	XX.250.T.9160	260	40	40	50	2,5	260	40	40	50	3,5
250	200	XX.250.T.9200	300	40	40	50	2,5	300	40	40	50	3,5
250	225	XX.250.T.9255	325	40	40	50	2,5	325	40	40	50	3,5
280	90	XX.280.T.9090	190	50	40	50	2,5	190	50	40	50	4,0
280	110	XX.280.T.9110	210	50	40	50	2,5	210	50	40	50	4,0
280	160	XX.280.T.9160	260	50	40	50	2,5	260	50	40	50	4,0
280	180	XX.280.T.9180	280	50	40	50	2,5	280	50	40	50	4,0
280	200	XX.280.T.9200	300	50	40	50	2,5	300	50	40	50	4,0
280	250	XX.280.T.9250	350	50	40	50	2,5	350	50	40	50	4,0
315	160	XX.315.T.9160	260	50	40	50	4,0	260	50	40	50	5,0
315	200	XX.315.T.9200	300	50	40	50	4,0	300	50	40	50	5,0
315	225	XX.315.T.9225	325	50	40	50	4,0	325	50	40	50	5,0
315	250	XX.315.T.9250	350	50	40	50	4,0	350	50	40	50	5,0
315	280	XX.315.T.9280	380	50	40	50	4,0	380	50	40	50	5,0
355	160	XX.355.T.9160	260	45	40	50	3,0	260	45	40	50	5,0
355	180	XX.355.T.9180	280	45	40	50	3,0	280	45	40	50	5,0
355	200	XX.355.T.9200	300	45	40	50	3,0	300	45	40	50	5,0
355	225	XX.355.T.9225	325	45	40	50	3,0	325	45	40	50	5,0
355	315	XX.355.T.9315	415	45	50	50	3,0	415	45	50	50	5,0
400	160	XX.400.T.9160	260	45	40	50	3,0	260	45	40	50	6,0
400	180	XX.400.T.9180	280	45	40	50	3,0	280	45	40	50	6,0
400	200	XX.400.T.9200	300	45	40	50	3,0	300	45	40	50	6,0
400	225	XX.400.T.9225	325	45	40	50	3,0	325	45	40	50	6,0
400	250	XX.400.T.9250	350	45	40	50	3,0	350	45	40	50	6,0
400	355	XX.400.T.9355	455	45	50	50	3,0	455	45	50	50	6,0
450	250	XX.450.T.9250	350	50	40	50	3,6	350	50	40	50	5,0
450	280	XX.450.T.9280	380	50	50	50	3,6	380	50	50	50	5,0
450	315	XX.450.T.9315	415	50	50	50	3,6	415	50	50	50	5,0
450	355	XX.450.T.9355	455	50	50	50	3,6	455	50	50	50	5,0
450	400	XX.450.T.9400	600	50	50	100	3,6	600	50	50	100	5,0
500	200	XX.500.T.9200	300	50	40	50	5,0	300	50	40	50	5,0
500	225	XX.500.T.9225	325	50	40	50	5,0	325	50	40	50	5,0
500	250	XX.500.T.9250	350	50	40	50	5,0	350	50	40	50	5,0
500	400	XX.500.T.9400	600	50	50	100	5,0	600	50	50	100	5,0
500	450	XX.500.T.9450	650	50	50	100	5,0	650	50	50	100	5,0
560	50	XX.560.T.9050	-	-	-	-	-	150	60	40	50	5,0
560	250	XX.560.T.9250	-	-	-	-	-	350	60	40	50	6,0
560	400	XX.560.T.9400	-	-	-	-	-	600	60	50	100	6,0
560	450	XX.560.T.9450	-	-	-	-	-	650	60	50	100	6,0
560	500	XX.560.T.9500	-	-	-	-	-	700	60	50	100	6,0

D1	D2	Nr kat.	PVC					PPs/PP-EL-s/ PP/PE				
			L	L1	L2	L3	s	L	L1	L2	L3	s
mm	mm	---	mm					mm				
600	110	XX.600.T.9110	210	60	40	50	5,0	210	60	40	50	6,0
600	400	XX.600.T.9400	600	60	50	100	5,0	600	60	50	100	6,0
600	450	XX.600.T.9450	650	60	50	100	5,0	650	60	50	100	6,0
600	500	XX.600.T.9500	700	60	50	100	5,0	700	60	50	100	6,0
600	560	XX.600.T.9560	-	-	-	-	-	760	60	60	100	6,0
630	250	XX.630.T.9250	-	-	-	-	-	350	70	40	50	6,0
630	400	XX.630.T.9400	-	-	-	-	-	600	70	50	100	6,0
630	450	XX.630.T.9450	-	-	-	-	-	650	70	50	100	6,0
700	400	XX.700.T.9400	540	70	50	60	6,0	600	70	50	100	6,0
700	450	XX.700.T.9450	586	70	50	68	6,0	650	70	50	100	6,0
700	600	XX.700.T.9600	780	70	60	90	6,0	800	70	60	100	6,0
700	630	XX.700.T.9630	-	-	-	-	-	830	70	70	150	6,0
710	450	XX.710.T.9450	-	-	-	-	-	650	80	50	100	6,0
710	500	XX.710.T.9500	-	-	-	-	-	700	80	50	100	6,0
710	630	XX.710.T.9630	-	-	-	-	-	830	80	70	100	6,0
800	500	XX.800.T.9500	650	80	50	75	8,0	700	80	50	100	8,0
800	700	XX.800.T.9700	910	80	70	105	8,0	900	80	70	100	8,0
800	710	XX.800.T.9710	-	-	-	-	-	910	80	80	100	8,0
900	500	XX.900.T.9500	650	90	50	75	8,0	700	90	50	100	8,0
1000	700	XX.1000.T.9700	910	100	70	105	10,0	900	100	70	100	10,0
1000	710	XX.1000.T.9710	-	-	-	-	-	910	100	80	100	10,0
1000	800	XX.1000.T.9800	1040	100	80	120	10,0	1100	100	80	150	10,0
1200	900	XX.1200.T.9900	1170	120	90	135	12,0	1200	120	90	150	12,0
1200	1000	XX.1200.T.91000	1300	120	100	150	12,0	1300	120	100	150	12,0
1250	250	XX.1250.T.9250	390	130	40	55	12,0	350	130	40	50	12,0
1250	500	XX.1250.T.9500	650	130	50	75	12,0	700	130	50	100	12,0
1250	900	XX.1250.T.9900	1170	130	90	135	12,0	1200	130	90	150	12,0
1250	1000	XX.1250.T.91000	1300	130	100	150	12,0	1300	130	100	150	12,0

**TABELA PREZENTUJE TYLKO WYBRANE MODELE.
PEŁEN ZAKRES ZAWIERA KARTA KATALOGOWA TRÓJNIKA REDUKCYJNEGO 90°**

DO POBRANIA ZE STRONY INTERNETOWEJ WWW.CHEMOWENT.PL - kliknij kod QR



Oznaczenia w tabeli:

- a. **D1, D2** - średnica zewnętrzna rur
- b. **L** - długość trójnika
- c. **L1, L2** - długość mufy
- d. **L3** - długość odejścia
- e. **XX** - oznaczenie materiału w systemie Chemowent

1.7. Trójnik okrągły redukcyjny 45°

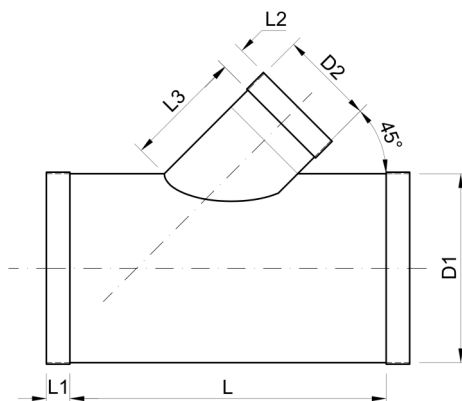
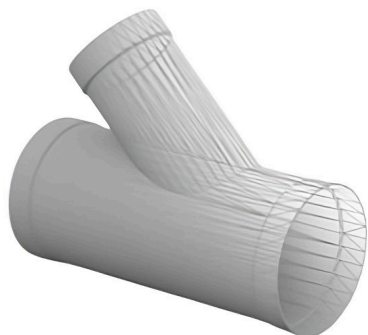

D1	D2	Nr kat.	PVC					PPs/PP-EL-s/ PP/PE				
			L	L1	L2	L3	s	L	L1	L2	L3	s
mm	mm	---	mm					mm				
63	50	XX.063.T.45050	170	40	40	100	2,5	170	40	40	100	3,0
75	50	XX.075.T.45050	170	35	40	100	2,5	170	40	40	100	3,0
75	63	XX.075.T.0063	190	35	40	115	2,5	190	40	40	115	3,0
90	50	XX.090.T.45050	170	35	40	100	2,5	170	40	40	100	3,0
90	63	XX.090.T.45063	190	35	40	115	2,5	190	40	40	115	3,0
90	75	XX.110.T.45063	205	35	35	125	2,5	205	40	40	125	3,0
110	50	XX.090.T.45075	170	35	40	100	2,5	170	40	40	100	3,0
110	90	XX.110.T.45090	230	35	35	140	2,5	230	40	40	140	3,0
125	75	XX.125.T.45075	205	35	35	125	2,5	205	40	40	125	3,0
125	90	XX.125.T.45090	230	35	35	140	2,5	230	40	40	140	3,0
125	110	XX.125.T.45110	255	35	35	160	2,5	255	40	40	160	3,0
140	110	XX.140.T.45110	255	35	35	160	2,5	255	40	40	160	3,0
140	125	XX.140.T.45125	280	35	35	175	2,5	280	40	40	175	3,0
160	50	XX.160.T.45050	170	35	40	100	2,5	170	40	40	100	3,0
160	125	XX.160.T.45125	280	35	35	175	2,5	280	40	40	175	3,0
160	140	XX.160.T.45140	290	35	35	190	2,5	290	40	40	190	3,0
180	110	XX.180.T.45110	255	35	35	160	2,5	255	50	40	160	3,0
180	125	XX.180.T.45125	280	35	35	175	2,5	280	40	40	175	3,0
180	160	XX.180.T.45160	325	35	35	210	2,5	325	40	40	210	3,0
200	50	XX.200.T.45050	170	35	40	100	2,5	170	40	40	100	4,0
200	110	XX.200.T.45110	255	35	35	160	2,5	255	40	40	160	4,0
200	125	XX.200.T.45125	280	35	35	175	2,5	280	40	40	175	4,0
200	160	XX.200.T.45160	325	35	35	210	2,5	325	40	40	210	4,0
225	90	XX.225.T.45090	230	35	35	140	2,5	230	40	40	140	3,5
225	110	XX.225.T.45110	255	35	35	160	2,5	255	40	40	160	3,5
225	160	XX.225.T.45160	325	35	35	210	2,5	325	40	40	210	3,5
225	180	XX.225.T.45180	355	35	35	230	2,5	355	40	40	230	3,5
225	200	XX.225.T.45200	380	35	35	250	2,5	380	40	40	250	3,5

D1	D2	Nr kat.	PVC					PPs/PP-EL-s/ PP/PE				
			L	L1	L2	L3	s	L	L1	L2	L3	s
mm	mm	---	mm					mm				
250	50	XX.250.T.45050	170	35	40	100	2,5	170	40	40	100	3,5
250	125	XX.250.T.45125	280	35	35	175	2,5	280	40	40	175	3,5
250	140	XX.250.T.45140	290	35	35	190	2,5	290	40	40	190	3,5
250	160	XX.250.T.45160	325	35	35	210	2,5	325	40	40	210	3,5
250	180	XX.250.T.45180	355	35	35	230	2,5	355	40	40	230	3,5
250	200	XX.250.T.45200	380	35	35	250	2,5	380	40	40	250	3,5
250	225	XX.250.T.45255	420	35	35	275	2,5	420	40	40	275	3,5
280	140	XX.280.T.45140	290	40	35	190	2,5	290	50	40	190	4,0
280	160	XX.280.T.45160	325	40	35	210	2,5	325	50	40	210	4,0
280	225	XX.280.T.45225	420	40	35	275	2,5	420	50	40	275	4,0
280	250	XX.280.T.45250	455	40	35	300	2,5	455	50	40	300	4,0
315	160	XX.315.T.45160	325	40	35	210	4,0	325	50	40	210	5,0
315	200	XX.315.T.45200	380	40	35	250	4,0	380	50	40	250	5,0
315	225	XX.315.T.45225	420	40	35	275	4,0	420	50	40	275	5,0
315	250	XX.315.T.45250	455	40	35	300	4,0	455	50	40	300	5,0
355	200	XX.355.T.45200	380	40	35	250	3,0	380	50	40	250	5,0
355	225	XX.355.T.45225	420	40	35	275	3,0	420	50	40	275	5,0
355	250	XX.355.T.45250	455	40	35	300	3,0	455	50	40	300	5,0
400	110	XX.400.T.45110	255	40	35	160	3,0	255	50	40	160	6,0
400	200	XX.400.T.45200	380	40	35	250	3,0	380	50	40	250	6,0
400	225	XX.400.T.45225	420	40	35	275	3,0	420	50	40	275	6,0
400	315	XX.400.T.45315	545	40	40	365	3,0	545	50	50	365	6,0
400	355	XX.400.T.45355	600	40	40	405	3,0	600	50	50	405	6,0
450	160	XX.450.T.45160	290	50	35	190	3,6	290	50	40	190	4,0
450	315	XX.450.T.45315	575	50	40	380	3,6	575	50	50	380	4,0
450	355	XX.450.T.45355	645	50	40	425	3,6	645	50	50	425	4,0
450	400	XX.450.T.45400	725	50	40	480	3,6	725	50	50	480	4,0
500	200	XX.500.T.45200	365	50	35	240	5,0	365	50	40	240	4,0
500	450	XX.500.T.45450	820	50	50	540	5,0	820	50	50	540	4,0
560	160	XX.560.T.45160	-	-	-	-	-	290	60	40	190	6,0
560	450	XX.560.T.45450	-	-	-	-	-	820	60	50	540	6,0
600	110	XX.600.T.45110	200	60	35	130	5,0	200	60	40	130	6,0
600	400	XX.600.T.45400	725	60	40	480	5,0	725	60	50	480	6,0
600	450	XX.600.T.45450	820	60	50	540	5,0	820	60	50	540	6,0
600	500	XX.600.T.45500	910	60	50	600	5,0	910	60	50	600	6,0
630	280	XX.630.T.45280	-	-	-	-	-	510	70	50	335	6,0
630	315	XX.630.T.45315	-	-	-	-	-	575	70	50	380	6,0
630	355	XX.630.T.45355	-	-	-	-	-	645	70	50	425	6,0
630	400	XX.630.T.45400	-	-	-	-	-	725	70	50	480	6,0
630	450	XX.630.T.45450	-	-	-	-	-	820	70	50	540	6,0

D1	D2	Nr kat.	PVC					PPs/PP-EL-s/ PP/PE				
			L	L1	L2	L3	s	L	L1	L2	L3	s
mm	mm	---	mm					mm				
700	140	XX.700.T.45140	255	70	35	170	6,0	255	70	40	170	6,0
700	160	XX.700.T.45160	290	70	35	190	6,0	290	70	40	190	6,0
700	600	XX.700.T.45600	1090	70	60	720	6,0	1090	70	60	720	6,0
710	200	XX.710.T.45200	-	-	-	-	-	365	80	40	240	6,0
710	225	XX.710.T.45225	-	-	-	-	-	410	80	40	270	6,0
710	700	XX.710.T.45700	-	-	-	-	-	1270	80	70	840	6,0
800	200	XX.800.T.45200	365	80	35	240	8,0	365	80	40	240	8,0
800	225	XX.800.T.45225	410	80	35	270	8,0	410	80	40	270	8,0
800	700	XX.800.T.45700	1270	80	70	840	8,0	1270	80	70	840	8,0
800	710	XX.800.T.45710	-	-	-	-	-	1290	80	80	850	8,0
900	400	XX.900.T.45400	725	90	40	480	8,0	725	90	50	480	8,0
900	450	XX.900.T.45450	820	90	50	540	8,0	820	90	50	540	8,0
1000	225	XX.1000.T.45225	410	100	35	270	10,0	410	100	40	270	10,0
1000	250	XX.1000.T.45250	455	100	35	300	10,0	455	100	40	300	10,0
1000	900	XX.1000.T.45900	1635	100	90	1080	10,0	1635	100	90	1080	10,0
1200	250	XX.1200.T.45250	455	120	35	300	12,0	455	120	40	300	12,0
1200	500	XX.1200.T.45500	910	120	50	600	12,0	910	120	50	600	12,0
1200	560	XX.1200.T.45560	-	-	-	-	-	1015	120	60	670	12,0
1200	600	XX.1200.T.45600	1090	120	60	720	12,0	1090	120	60	720	12,0
1200	630	XX.1200.T.45630	-	-	-	-	-	1145	120	70	755	12,0
1250	355	XX.1250.T.45355	645	130	40	425	12,0	645	130	50	425	12,0
1250	400	XX.1250.T.45400	725	130	40	480	12,0	725	130	50	480	12,0
1250	450	XX.1250.T.45450	820	130	50	540	12,0	820	130	50	540	12,0
1250	500	XX.1250.T.45500	910	130	50	600	12,0	910	130	50	600	12,0
1250	560	XX.1250.T.45560	-	-	-	-	-	1015	130	60	670	12,0
1250	1000	XX.1250.T.451000	1815	130	100	1200	12,0	1815	130	100	1200	12,0
1250	1200	XX.1250.T.451200	2180	130	120	1440	12,0	2180	130	120	1440	12,0

**TABELA PREZENTUJE TYLKO WYBRANE MODELE.
PEŁEN ZAKRES ZAWIERA KARTA KATALOGOWA TRÓJNIKA REDUKCYJNEGO 45°**

DO POBRANIA ZE STRONY INTERNETOWEJ WWW.CHEMOWENT.PL - kliknij kod QR



Oznaczenia w tabeli:

- D1, D2 - średnica zewnętrzna rur
- L - długość trójnika
- L1, L2 - długość mufy
- L3 - długość odejścia
- XX - oznaczenie materiału w systemie Chemowent

1.8. Trójnik okrągły orłowy 90°

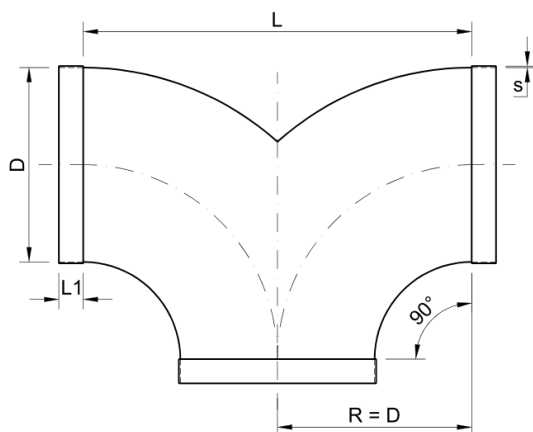

D	Nr kat.	L1	L	PVC	PPs/PP-EL-s/ PP/PE
				s	
mm	---	mm	mm	mm	mm
75	XX.075.Y.9000	40	150	2,50	3,00
90	XX.090.Y.9000	40	180	2,50	3,00
110	XX.110.Y.9000	40	220	2,50	3,00
125	XX.125.Y.9000	40	250	2,50	3,00
140	XX.140.Y.9000	40	280	2,50	3,00
160	XX.160.Y.9000	40	320	2,50	3,00
180	XX.180.Y.9000	40	360	2,50	3,00
200	XX.200.Y.9000	40	400	2,50	4,00
225	XX.225.Y.9000	40	450	2,50	4,00
250	XX.250.Y.9000	40	500	2,50	4,00
280	XX.280.Y.9000	50	560	2,50	4,00
315	XX.315.Y.9000	50	630	4,00	5,00
355	XX.355.Y.9000	50	710	3,00	5,00
400	XX.400.Y.9000	50	800	3,00	6,00
450	XX.450.Y.9000	50	900	3,60	5,00
500	XX.500.Y.9000	50	1000	5,00	5,00
560	XX.560.Y.9000	60	-	-	6,00
600	XX.600.Y.9000	60	1200	5,00	6,00
630	XX.630.Y.9000	70	-	-	6,00
700	XX.700.Y.9000	70	1400	6,00	6,00
710	XX.710.Y.9000	80	-	-	6,00
800	XX.800.Y.9000	80	1600	8,00	8,00
900	XX.900.Y.9000	90	1800	8,00	8,00
1000	XX.1000.Y.9000	100	2000	10,00	10,00
1200	XX.1200.Y.9000	120	2400	12,00	12,00
1250	XX.1250.Y.9000	130	2500	12,00	12,00

Oznaczenia w tabeli:

- a. **D** - średnica zewnętrzna rury
- b. **s** - grubość ścianki
- c. **L1** - długość mufy
- d. **L** - długość trójnika
- e. **XX** - oznaczenie materiału w systemie Chemowent

Współczynnik oporów miejscowych [ζ]: 0,25

1.9. Trójnik okrągły orłowy 45°

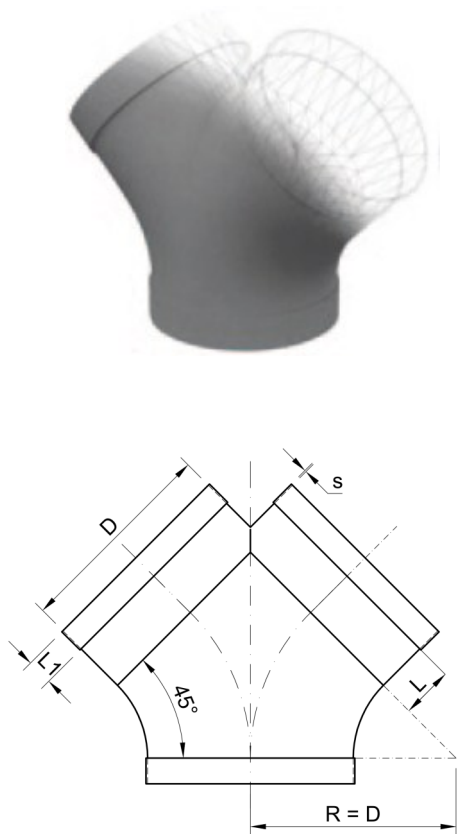

D	Nr kat.	L1	L	PVC	PPs/PP-EL-s/ PP/PE
				s	
mm	---	mm	mm	mm	mm
75	XX.075.Y.4500	40	40	1,80	3,00
90	XX.090.Y.4500	40	40	1,80	3,00
110	XX.110.Y.4500	40	60	1,80	3,00
125	XX.125.Y.4500	40	60	1,80	3,00
140	XX.140.Y.4500	40	60	1,80	3,00
160	XX.160.Y.4500	40	60	1,80	3,00
180	XX.180.Y.4500	40	60	1,80	3,00
200	XX.200.Y.4500	40	80	1,80	3,00
225	XX.225.Y.4500	40	80	1,80	3,50
250	XX.250.Y.4500	40	80	2,00	3,50
280	XX.280.Y.4500	50	80	2,30	3,50
315	XX.315.Y.4500	50	100	2,50	4,00
355	XX.355.Y.4500	50	100	2,90	4,00
400	XX.400.Y.4500	50	100	3,20	4,50
450	XX.450.Y.4500	50	150	3,60	5,00
500	XX.500.Y.4500	50	150	5,00	5,00
560	XX.560.Y.4500	60	200	-	6,00
600	XX.600.Y.4500	60	200	5,00	6,00
630	XX.630.Y.4500	70	200	-	6,00
700	XX.700.Y.4500	70	250	6,00	6,00
710	XX.710.Y.4500	80	250	-	6,00
800	XX.800.Y.4500	80	300	8,00	8,00
900	XX.900.Y.4500	90	300	8,00	8,00
1000	XX.1000.Y.4500	100	350	10,00	10,00
1200	XX.1200.Y.4500	120	350	12,00	12,00
1250	XX.1250.Y.4500	130	350	12,00	12,00

Oznaczenia w tabeli:

- a. **D** - średnica zewnętrzna rury
- b. **s** - grubość ścianki
- c. **L1** - długość mufy
- d. **L** - długość odejścia trójnika
- e. **XX** - oznaczenie materiału w systemie Chemowent

Współczynnik oporów miejscowych [ζ]: 0,15

1.10. Mufa okrągła

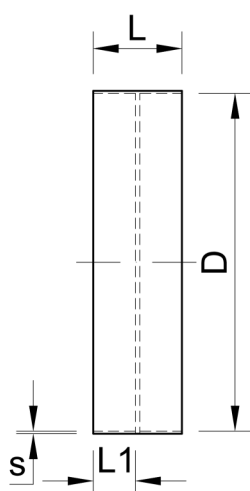
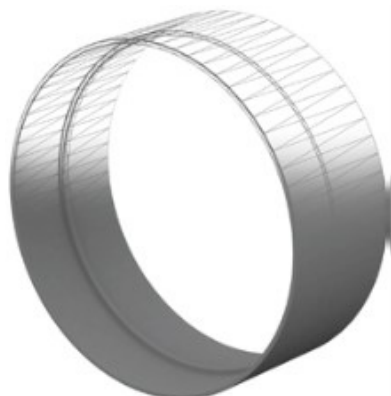

D	Nr kat.	L1	L	PVC	PPs/PP-EL-s/ PP/PE
				s	
mm	---	mm	mm	mm	mm
50	XX.050.L.0002	-	45*	2,50	3,00
63	XX.063.L.0002	-	45*	2,50	3,00
75	XX.075.L.0002	40	85	2,50	3,00
90	XX.090.L.0002	40	85	2,50	3,00
110	XX.110.L.0002	40	85	2,50	3,00
125	XX.125.L.0002	40	85	2,50	3,00
140	XX.140.L.0002	40	85	2,50	3,00
160	XX.160.L.0002	40	85	2,50	3,00
180	XX.180.L.0002	40	85	2,50	3,00
200	XX.200.L.0002	40	85	2,50	3,00
225	XX.225.L.0002	40	85	2,50	3,50
250	XX.250.L.0002	40	85	2,50	3,50
280	XX.280.L.0002	50	105	2,50	3,50
315	XX.315.L.0002	50	105	2,50	4,00
355	XX.355.L.0002	50	105	3,00	4,00
400	XX.400.L.0002	50	105	3,00	4,50
450	XX.450.L.0002	55	120	5,00	5,00
500	XX.500.L.0002	55	120	5,00	5,00
560	XX.560.L.0002	-	120	-	5,00
600	XX.600.L.0002	55	120	6,00	6,00
630	XX.630.L.0002	-	120	-	6,00
700	XX.700.L.0002	70	150	6,00	6,00
710	XX.710.L.0002	-	170	-	6,00
800	XX.800.L.0002	80	170	8,00	8,00
900	XX.900.L.0002	90	190	8,00	8,00
1000	XX.1000.L.0002	100	210	10,00	10,00
1200	XX.1200.L.0002	120	250	12,00	12,00
1250	XX.1250.L.0002	130	270	12,00	12,00

Oznaczenia w tabeli:

- a. **D** - średnica zewnętrzna rury
- b. **s** - grubość ścianki
- c. **L1** - długość mufy
- d. **L** - całkowita długość mufy
- e. **XX** - oznaczenie materiału w systemie Chemowent

1.11 Redukcja okrągła

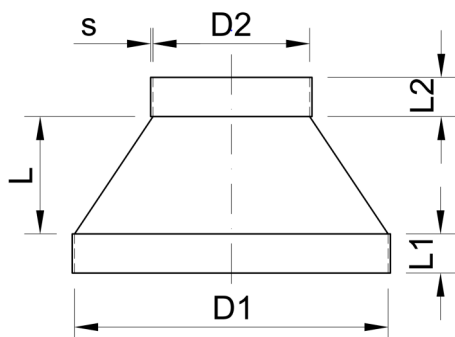
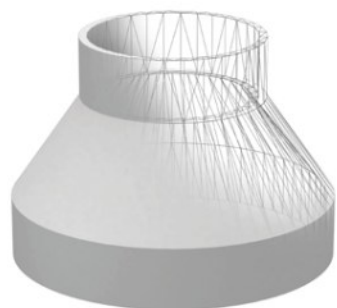

$D1 - D2 / \zeta=0 - 0,5$

D1	D2	Nr kat.	L	L1	L2	PVC	PPs/PP-EL-s/ PP/PE
mm	mm	---	mm	mm	mm		s mm
75	50	XX.075.R.0050	40	40	25	2,5	2,5
90	50	XX.090.R.0050	60	40	25	2,5	2,5
110	50	XX.110.R.0050	100	40	25	2,5	2,5
75	63	XX.075.R.0063	40	40	25	2,5	2,5
90	63	XX.090.R.0063	60	40	25	2,5	2,5
110	63	XX.110.R.0063	100	40	25	2,5	2,5
90	75	XX.090.R.0075	40	40	40	2,5	2,5
110	75	XX.110.R.0075	80	40	40	2,5	2,5
125	75	XX.125.R.0075	120	40	40	2,5	2,5
110	90	XX.110.R.0090	60	40	40	2,5	2,5
125	90	XX.125.R.0090	100	40	40	2,5	2,5
125	110	XX.125.R.0110	40	40	40	2,5	2,5
140	110	XX.140.R.0110	80	40	40	2,5	2,5
160	110	XX.160.R.0110	140	40	40	2,5	2,5
180	110	XX.180.R.0110	50	40	40	2,5	2,5
200	110	XX.200.R.0110	65	40	40	2,5	2,5
140	125	XX.140.R.0125	40	40	40	2,5	2,5
160	125	XX.160.R.0125	100	40	40	2,5	2,5
180	125	XX.180.R.0125	40	40	40	2,5	2,5
200	125	XX.200.R.0125	55	40	40	2,5	2,5
225	125	XX.225.R.0125	65	40	40	2,5	2,5
250	125	XX.250.R.0125	90	40	40	2,5	2,5
160	140	XX.160.R.0140	60	40	40	2,5	2,5
180	140	XX.180.R.0140	30	40	40	2,5	2,5
200	140	XX.200.R.0140	45	40	40	2,5	2,5
225	140	XX.225.R.0140	60	40	40	2,5	2,5

D1	D2	Nr kat.	L	L1	L2	PVC	PPs/PP-EL-s/ PP/PE
mm	mm	---	mm	mm	mm		s mm
250	140	XX.250.R.0140	80	40	40	2,5	2,5
180	160	XX.180.R.0160	60	40	40	2,5	2,5
200	160	XX.200.R.0160	120	40	40	2,5	2,5
225	160	XX.225.R.0160	100	40	40	2,5	2,5
250	160	XX.250.R.0160	120	40	40	2,5	2,5
280	160	XX.280.R.0160	85	50	40	2,5	2,5
315	160	XX.315.R.0160	115	50	40	2,5	2,5
200	180	XX.200.R.0180	75	40	40	2,5	2,5
225	180	XX.225.R.0180	85	40	40	2,5	2,5
250	180	XX.250.R.0180	100	40	40	2,5	2,5
280	180	XX.280.R.0180	65	50	40	2,5	2,5
315	180	XX.315.R.0180	100	50	40	2,5	2,5
225	200	XX.225.R.0200	80	40	40	2,5	2,5
250	200	XX.250.R.0200	140	40	40	2,5	2,5
280	200	XX.280.R.0200	105	50	40	2,5	2,5
315	200	XX.315.R.0200	160	50	40	2,5	2,5
355	200	XX.355.R.0200	115	50	40	2,5	2,5
400	200	XX.400.R.0200	147	50	40	2,5	2,5
250	225	XX.250.R.0225	80	40	40	2,5	2,5
280	225	XX.280.R.0225	40	50	40	2,5	2,5
315	225	XX.315.R.0225	65	50	40	2,5	2,5
355	225	XX.355.R.0225	95	50	40	2,5	2,5
400	225	XX.400.R.0225	125	50	40	2,5	2,5
280	250	XX.280.R.0250	35	50	40	2,5	2,5
315	250	XX.315.R.0250	100	50	40	2,5	2,5
355	250	XX.355.R.0250	140	50	40	2,5	2,5
400	250	XX.400.R.0250	105	50	40	2,5	2,5
450	250	XX.450.R.0250	145	50	40	2,5	2,5
315	280	XX.315.R.0280	100	50	50	2,5	2,5
355	280	XX.355.R.0280	65	50	50	2,5	2,5
400	280	XX.400.R.0280	90	50	50	2,5	2,5
450	280	XX.450.R.0280	120	50	50	2,5	2,5
500	280	XX.500.R.0280	160	50	50	2,5	2,5
355	315	XX.355.R.0315	120	50	50	2,5	2,5
400	315	XX.400.R.0315	120	50	50	2,5	2,5
450	315	XX.450.R.0315	95	50	50	2,5	2,5
500	315	XX.500.R.0315	135	50	50	2,5	2,5
400	355	XX.400.R.0355	135	50	50	3,0	3,0
450	355	XX.450.R.0355	75	50	50	3,0	3,0
500	355	XX.500.R.0355	110	50	50	3,0	3,0

D1	D2	Nr kat.	L	L1	L2	PVC	PPs/PP-EL-s/ PP/PE
mm	mm	---	mm	mm	mm		s mm
560	355	XX.560.R.0355	180	60	50	3,0	3,0
600	355	XX.600.R.0355	215	60	50	3,0	3,0
630	355	XX.630.R.0355	240	60	50	3,0	3,0
700	355	XX.700.R.0355	300	70	50	3,0	3,0
710	355	XX.710.R.0355	310	70	50	3,0	3,0
800	355	XX.800.R.0355	385	80	50	3,0	3,0
900	355	XX.900.R.0355	475	90	50	3,0	3,0
1000	355	XX.1000.R.0355	560	100	50	3,0	3,0
450	400	XX.450.R.0400	45	50	50	3,0	3,0
500	400	XX.500.R.0400	80	50	50	3,0	3,0
560	400	XX.560.R.0400	140	60	50	3,0	3,0
600	400	XX.600.R.0400	175	60	50	3,0	3,0
630	400	XX.630.R.0400	205	60	50	3,0	3,0
700	400	XX.700.R.0400	265	70	50	3,0	3,0
710	400	XX.710.R.0400	270	70	50	3,0	3,0
800	400	XX.800.R.0400	350	80	50	3,0	3,0
900	400	XX.900.R.0400	435	90	50	3,0	3,0
1000	400	XX.1000.R.0400	520	100	50	3,0	3,0
500	450	XX.500.R.0450	45	50	50	5,0	5,0
560	450	XX.560.R.0450	100	60	50	5,0	5,0
600	450	XX.600.R.0450	130	60	50	5,0	5,0
630	450	XX.630.R.0450	160	60	50	5,0	5,0
700	450	XX.700.R.0450	220	70	50	5,0	5,0
710	450	XX.710.R.0450	230	70	50	5,0	5,0
800	450	XX.800.R.0450	305	80	50	5,0	5,0
900	450	XX.900.R.0450	395	90	50	5,0	5,0
1000	450	XX.1000.R.0450	480	100	50	5,0	5,0
560	500	XX.560.R.0500	55	60	50	5,0	5,0
600	500	XX.600.R.0500	90	60	50	5,0	5,0
630	500	XX.630.R.0500	115	60	50	5,0	5,0
700	500	XX.700.R.0500	175	70	50	5,0	5,0
710	500	XX.710.R.0500	185	70	50	5,0	5,0
800	500	XX.800.R.0500	265	80	50	5,0	5,0
900	500	XX.900.R.0500	350	90	50	5,0	5,0
1000	500	XX.1000.R.0500	435	100	50	5,0	5,0
600	560	XX.600.R.0560	40	60	60	6,0	6,0
630	560	XX.630.R.0560	65	60	60	6,0	6,0
700	560	XX.700.R.0560	125	70	60	6,0	6,0
710	560	XX.710.R.0560	135	70	60	6,0	6,0
800	560	XX.800.R.0560	215	80	60	6,0	6,0

D1	D2	Nr kat.	L	L1	L2	PVC	PPs/PP-EL-s/ PP/PE
mm	mm	---	mm	mm	mm	s mm	
900	560	XX.900.R.0560	300	90	60	6,0	6,0
1000	560	XX.1000.R.0560	385	100	60	6,0	6,0
630	600	XX.630.R.0600	30	60	60	6,0	6,0
700	600	XX.700.R.0600	90	70	60	6,0	6,0
710	600	XX.710.R.0600	100	70	60	6,0	6,0
800	600	XX.800.R.0600	180	80	60	6,0	6,0
900	600	XX.900.R.0600	265	90	60	6,0	6,0
1000	600	XX.1000.R.0600	350	100	60	6,0	6,0
1200	600	XX.1200.R.0600	525	120	60	6,0	6,0
1250	600	XX.1250.R.0600	570	130	60	6,0	6,0
700	630	XX.700.R.0630	65	70	60	6,0	6,0
710	630	XX.710.R.0630	75	70	60	6,0	6,0
800	630	XX.800.R.0630	155	80	60	6,0	6,0
900	630	XX.900.R.0630	240	90	60	6,0	6,0
1000	630	XX.1000.R.0630	325	100	60	6,0	6,0
1200	630	XX.1200.R.0630	500	120	60	6,0	6,0
1250	630	XX.1250.R.0630	540	130	60	6,0	6,0
710	700	XX.710.R.0700	15	70	70	6,0	6,0
800	700	XX.800.R.0700	90	80	70	6,0	6,0
900	700	XX.900.R.0700	180	90	70	6,0	6,0
1000	700	XX.1000.R.0700	265	100	70	6,0	6,0
1200	700	XX.1200.R.0700	440	120	70	6,0	6,0
1250	700	XX.1250.R.0700	480	130	70	6,0	6,0
800	710	XX.800.R.0710	85	80	70	8,0	8,0
900	710	XX.900.R.0710	170	90	70	8,0	8,0
1000	710	XX.1000.R.0710	255	100	70	8,0	8,0
1200	710	XX.1200.R.0710	430	120	70	8,0	8,0
1250	710	XX.1250.R.0710	475	130	70	8,0	8,0
900	800	XX.900.R.0800	90	90	80	8,0	8,0
1000	800	XX.1000.R.0800	180	100	80	8,0	8,0
1200	800	XX.1200.R.0800	350	120	80	8,0	8,0
1250	800	XX.1250.R.0800	395	130	80	8,0	8,0
1000	900	XX.1000.R.0900	90	100	90	8,0	8,0
1200	900	XX.1200.R.0900	265	120	90	8,0	8,0
1250	900	XX.1250.R.0900	310	130	90	8,0	8,0
1200	1000	XX.1200.R.01000	180	120	100	10,0	10,0
1250	1000	XX.1250.R.01000	220	130	100	10,0	10,0
1250	1200	XX.1250.R.01200	50	130	130	10,0	10,0

Oznaczenia w tabeli

a. **D1, D2** - średnica zewnętrzna rury
 b. **L** - długość redukcji

c. **L1, L2** - długość mufy
 d. **XX** - oznaczenie materiału w systemie Chemowent

1.12. Kołnierz mufowy

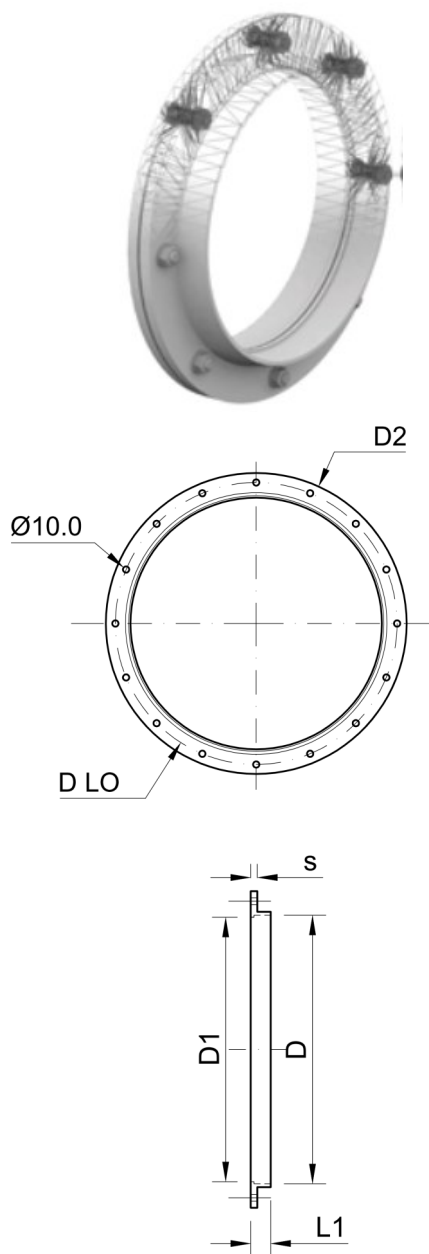

D	Nr kat.	D LO	D2	LO	D1	L1	s
mm	---	mm	mm	szt.	mm	mm	mm
50	XX.050.L.0004	95	125	8	47	30	8
63	XX.063.L.0004	102	132	8	58	30	8
75	XX.075.L.0004	110	140	8	69	29	8
90	XX.090.L.0004	128	158	8	84	29	8
110	XX.110.L.0004	150	170	8	106	30	8
125	XX.125.L.0004	165	185	8	122	30	8
140	XX.140.L.0004	175	200	8	136	30	8
160	XX.160.L.0004	200	230	8	156	30	8
180	XX.180.L.0004	220	245	8	176	30	8
200	XX.200.L.0004	240	270	8	196	30	8
225	XX.225.L.0004	265	290	8	222	30	8
250	XX.250.L.0004	290	320	12	246	30	8
280	XX.280.L.0004	325	355	12	275	30	10
315	XX.315.L.0004	350	380	12	310	30	10
355	XX.355.L.0004	400	435	12	349	30	10
400	XX.400.L.0004	445	475	16	393	30	10
450	XX.450.L.0004	510	560	16	446	60	12
500	XX.500.L.0004	560	610	20	496	60	12
560	XX.560.L.0004	610	660	20	556	60	12
600	XX.600.L.0004	660	710	24	596	80	12
630	XX.630.L.0004	710	760	24	626	80	12
700	XX.700.L.0004	760	810	24	696	80	12
710	XX.710.L.0004	760	810	24	706	80	12
800	XX.800.L.0004	866	916	28	796	80	12
900	XX.900.L.0004	966	1016	32	896	100	12
1000	XX.1000.L.0004	1066	1116	36	993	100	12
1200	XX.1200.L.0004	1270	1320	40	1193	120	12
1250	XX.1250.L.0004	1320	1370	44	1242	130	12

Oznaczenia w tabeli:

- D - średnica zewnętrzna rury
- D LO - średnica rozstawu otworów
- D2 - średnica zewnętrzna kołnierza
- LO - ilość otworów
- L1 - szerokość kołnierza
- s - grubość kołnierza
- XX - oznaczenie materiału w systemie Chemowent

1.13. Kołnierz luźny

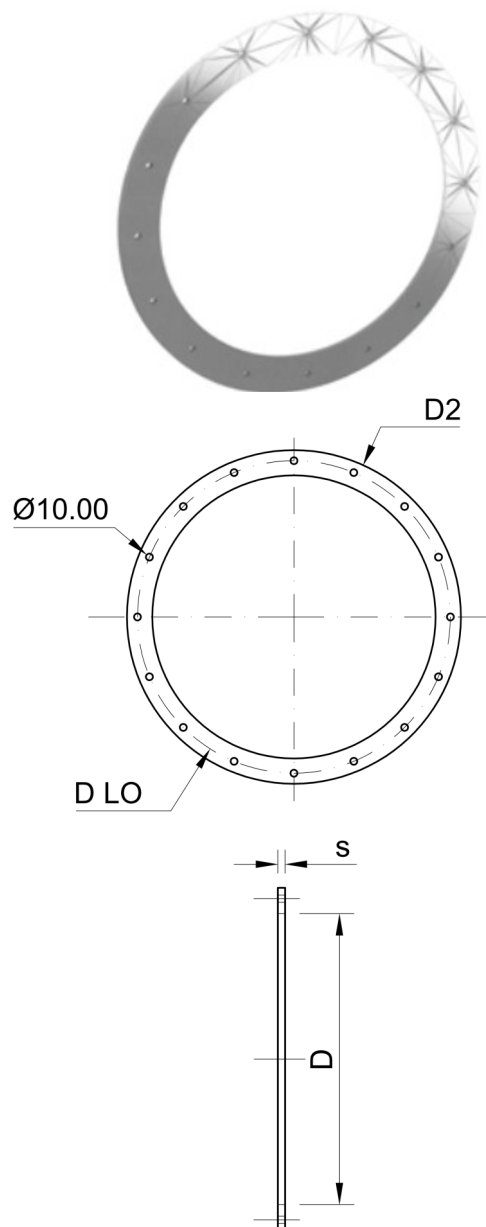

D	Nr kat.	D LO	D2	LO	s
mm	---	mm	mm	szt.	mm
50	XX.050.L.0044	95	125	8	8
63	XX.063.L.0044	102	132	8	8
75	XX.075.L.0044	110	140	8	8
90	XX.090.L.0044	128	158	8	8
110	XX.110.L.0044	150	170	8	8
125	XX.125.L.0044	165	185	8	8
140	XX.140.L.0044	175	200	8	8
160	XX.160.L.0044	200	230	8	8
180	XX.180.L.0044	220	250	8	8
200	XX.200.L.0044	240	270	8	8
225	XX.225.L.0044	265	295	8	8
250	XX.250.L.0044	290	320	12	8
280	XX.280.L.0044	325	355	12	10
315	XX.315.L.0044	350	395	12	10
355	XX.355.L.0044	400	435	12	10
400	XX.400.L.0044	445	475	16	10
450	XX.450.L.0044	510	560	16	12
500	XX.500.L.0044	560	610	20	12
560	XX.560.L.0044	610	660	20	12
600	XX.600.L.0044	660	710	24	12
630	XX.630.L.0044	710	760	24	12
700	XX.700.L.0044	760	810	24	12
710	XX.710.L.0044	760	810	24	12
800	XX.800.L.0044	866	916	28	12
900	XX.900.L.0044	966	1016	32	12
1000	XX.1000.L.0044	1066	1116	36	12
1200	XX.1200.L.0044	1270	1320	40	12
1250	XX.1250.L.0044	1320	1370	44	12

Oznaczenia w tabeli:

- a. **D** - średnica zewnętrzna rury
- b. **D LO** - średnica rozstawu otworów
- c. **D2** - średnica zewnętrzna kołnierza
- d. **LO** - ilość otworów
- e. **s** - grubość kołnierza
- g. **XX** - oznaczenie materiału w systemie Chemowent

1.14. Kołnierz ślepy

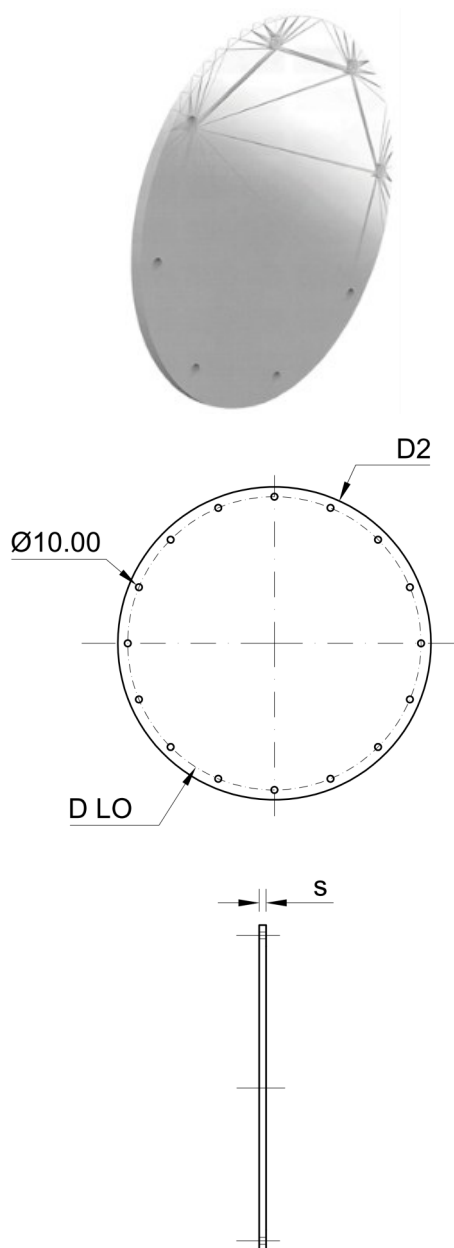

D	Nr kat.	D LO	D2	LO	s
mm	---	mm	mm	szt	mm
50	XX.050.L.2568	95	125	8	8
63	XX.063.L.2568	102	132	8	8
75	XX.075.L.2568	110	140	8	8
90	XX.090.L.2568	128	158	8	8
110	XX.110.L.2568	150	170	8	8
125	XX.125.L.2568	165	185	8	8
140	XX.140.L.2568	175	200	8	8
160	XX.160.L.2568	200	230	8	8
180	XX.180.L.2568	220	250	8	8
200	XX.200.L.2568	240	270	8	8
225	XX.225.L.2568	265	295	8	8
250	XX.250.L.2568	290	320	12	8
280	XX.280.L.2568	325	355	12	10
315	XX.315.L.2568	350	395	12	10
355	XX.355.L.2568	400	435	12	10
400	XX.400.L.2568	445	475	16	10
450	XX.450.L.2568	510	560	16	12
500	XX.500.L.2568	560	610	20	12
560	XX.560.L.2568	610	660	20	12
600	XX.600.L.2568	660	710	24	12
630	XX.630.L.2568	710	760	24	12
700	XX.700.L.2568	760	810	24	12
710	XX.710.L.2568	760	810	24	12
800	XX.800.L.2568	866	916	28	12
900	XX.900.L.2568	966	1016	32	12
1000	XX.1000.L.2568	1066	1116	36	12
1200	XX.1200.L.2568	1270	1320	40	12
1250	XX.1250.L.2568	1320	1370	44	12

Oznaczenia w tabeli:

- a. **D** - średnica zewnętrzna rury
- b. **D LO** - średnica rozstawu otworów
- c. **D2** - średnica zewnętrzna kołnierza
- d. **LO** - ilość otworów
- e. **s** - grubość kołnierza
- g. **XX** - oznaczenie materiału w systemie Chemowent

1.15. Uszczelka EPDM do kołnierzy

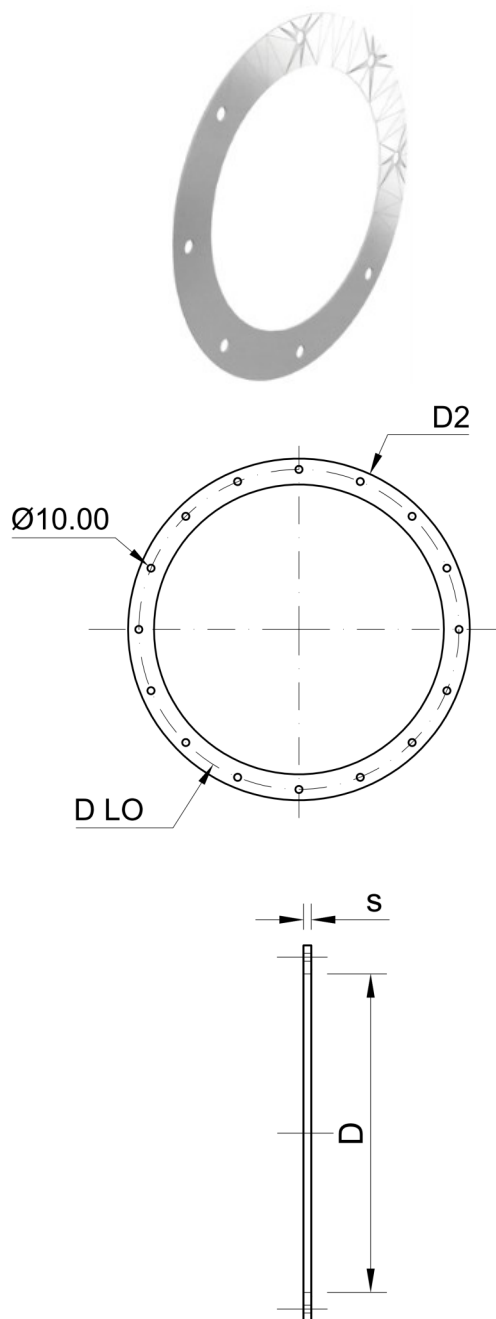

D	Nr kat.	D LO	D2	LO	s
mm	---	mm	mm	szt	mm
50	22.050.U.0000	95	125	8	3
63	22.063.U.0000	102	132	8	3
75	22.075.U.0000	110	140	8	3
90	22.090.U.0000	128	158	8	3
110	22.110.U.0000	150	170	8	3
125	22.125.U.0000	165	185	8	3
140	22.140.U.0000	175	200	8	3
160	22.160.U.0000	200	230	8	3
180	22.180.U.0000	220	250	8	3
200	22.200.U.0000	240	270	8	3
225	22.225.U.0000	265	295	8	3
250	22.250.U.0000	290	320	12	3
280	22.280.U.0000	325	355	12	3
315	22.315.U.0000	350	395	12	3
355	22.355.U.0000	400	435	12	3
400	22.400.U.0000	445	475	16	3
450	22.450.U.0000	510	560	16	3
500	22.500.U.0000	560	610	20	3
560	22.560.U.0000	610	660	20	3
600	22.600.U.0000	660	710	24	3
630	22.630.U.0000	710	760	24	3
700	22.700.U.0000	760	810	24	3
710	22.710.U.0000	760	810	24	3
800	22.800.U.0000	866	916	28	3
900	22.900.U.0000	966	1016	32	3
1000	22.1000.U.0000	1066	1116	36	3
1200	22.1200.U.0000	1270	1320	40	3
1250	22.1250.U.0000	1320	1370	44	3

Oznaczenia w tabeli:

- a. **D** - średnica zewnętrzna rury
- b. **D LO** - średnica rozstawu otworów
- c. **D2** - średnica zewnętrzna uszczelki
- d. **LO** - ilość otworów
- e. **s** - grubość uszczelki

1.16. Przepustnica regulacyjna ręczna mufowa

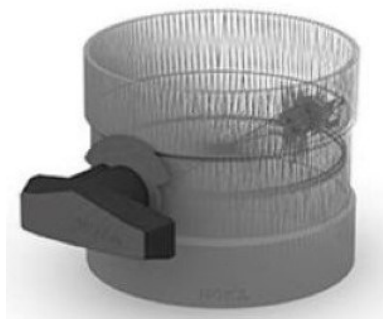

* dźwignia podłużna i regulacja co 15°

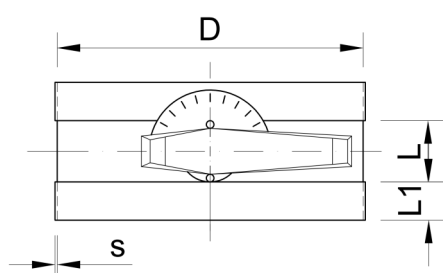

D	Nr kat.	L1	L	PVC	PPs/PP-EL-s/ PP/PE
				s	
mm	---	mm	mm	mm	mm
50	XX.050.L.0070	35	60	3,0	3,0
63	XX.063.L.0070	35	60	3,0	3,0
75	XX.075.L.0070	35	60	3,0	3,0
90	XX.090.L.0070	35	60	3,0	3,0
110	XX.110.L.0070	40	75	3,0	3,0
125	XX.125.L.0070	40	70	3,0	3,0
140	XX.140.L.0070	40	70	3,0	3,0
160	XX.160.L.0070	40	70	3,0	4,0
180	XX.180.L.0070	50	70	3,0	4,0
200	XX.200.L.0070	50	70	3,0	4,0
225	XX.225.L.0070	50	70	3,0	4,0
250	XX.250.L.0070	50	70	3,0	4,0
280	XX.280.L.0070	50	70	3,0	4,0
315	XX.315.L.0070	50	70	3,0	4,0
355	XX.355.L.0070	50	75	4,0	4,0
400	XX.400.L.0070	50	80	4,0	4,0



dźwignia podłużna i regulacja płynna

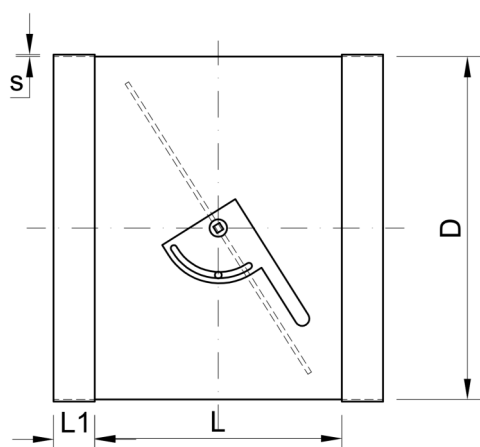

D	Nr kat.	L1	L	PVC	PPs/PP-EL-s/ PP/PE
				s	
mm	---	mm	mm	mm	mm
450	XX.450.L.0070	60	320	3,6	5,0
500	XX.500.L.0070	60	360	4,0	5,0
560	XX.560.L.0070	70	410	-	6,0
600	XX.600.L.0070	70	450	5,0	6,0
630	XX.630.L.0070	70	480	-	6,0
700	XX.700.L.0070	70	520	6,0	8,0
710	XX.710.L.0070	80	530	-	8,0
800	XX.800.L.0070	80	560	8,0	8,0
900	XX.900.L.0070	90	650	8,0	10,0
1000	XX.1000.L.0070	100	740	10,0	10,0
1200	XX.1200.L.0070	120	960	12,0	12,0
1250	XX.1250.L.0070	130	960	12,0	12,0

Oznaczenia w tabeli:

- a. **D** - średnica zewnętrzna rury
- b. **L** - długość korpusu przepustnicy
- c. **L1** - długość mufy
- d. **s** - grubość ścianki
- e. **XX** - oznaczenie materiału w systemie Chemowent

* do przepustnic w zakresie średnic d50 – d400 dostępna jest dodatkowa opcja pokrętła - z regulacją płynną.

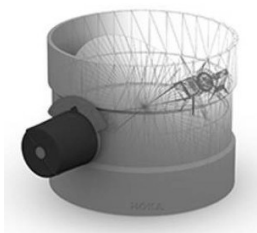

W zakresie średnic d50 - d400 istnieje możliwość modyfikacji przepustnicy pod napęd elektryczny.

W zakresie średnic d110 – d1250 możliwe jest wykonanie przepustnicy z uszczelką EPDM

d110 - d400

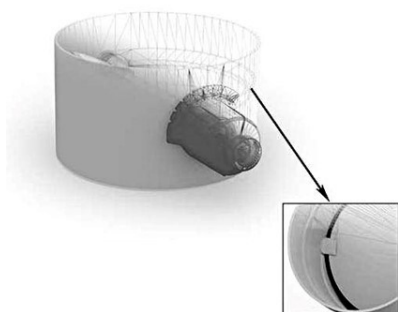

d450 - d1250

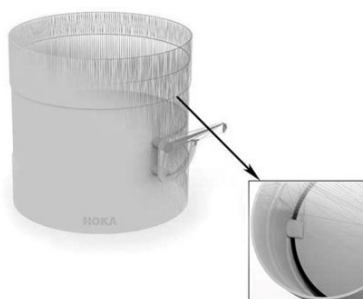

Współczynnik oporów miejscowych dla przepustnic wentylacyjnych zależy m.in. od stopnia otwarcia. Zależność tę prezentuje tabela:

ζ przy ustawieniach kłapy	0,5	1,5	4	11	33	120	250
	10°	20°	30°	40°	50°	60°	70°

1.17. Przepustnica regulacyjna ręczna kołnierzowa



* dźwignia podłużna i regulacja co 15°

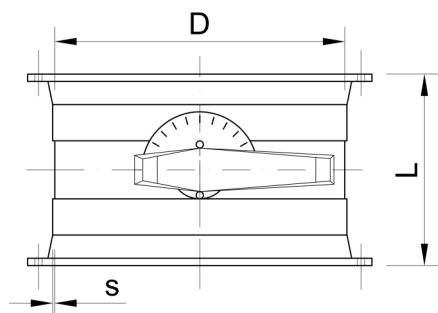

D	Nr kat.	L	PVC	PPs/PP-EL-s/ PP/PE
			s	
mm	---	mm	mm	mm
75	XX.075.L.0170	188	3,0	3,0
90	XX.090.L.0170	188	3,0	3,0
110	XX.110.L.0170	215	3,0	3,0
125	XX.125.L.0170	210	3,0	3,0
140	XX.140.L.0170	210	3,0	3,0
160	XX.160.L.0170	210	3,0	4,0
180	XX.180.L.0170	230	3,0	4,0
200	XX.200.L.0170	230	3,0	4,0
225	XX.225.L.0170	230	3,0	4,0
250	XX.250.L.0170	230	3,0	4,0
280	XX.280.L.0170	230	3,0	4,0
315	XX.315.L.0170	230	3,0	4,0
355	XX.355.L.0170	235	4,0	4,0
400	XX.400.L.0170	240	4,0	4,0



dźwignia podłużna i regulacja płynna

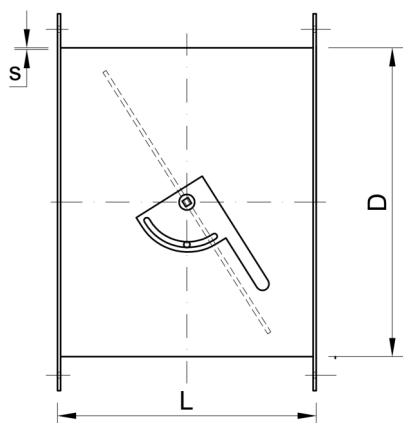

D	Nr kat.	L	PVC	PPs/PP-EL-s/ PP/PE
			s	
mm	---	mm	mm	mm
450	XX.450.L.0170	378	3,6	5,0
500	XX.500.L.0170	418	4,0	5,0
560	XX.560.L.0170	418	-	6,0
600	XX.600.L.0170	458	5,0	6,0
630	XX.630.L.0170	488	-	6,0
700	XX.700.L.0170	528	6,0	8,0
710	XX.710.L.0170	538	-	8,0
800	XX.800.L.0170	568	8,0	8,0
900	XX.900.L.0170	658	8,0	10,0
1000	XX.1000.L.0170	748	10,0	10,0
1200	XX.1200.L.0170	968	12,0	12,0
1250	XX.1250.L.0170	968	12,0	12,0

Oznaczenia w tabeli:

- a. **D** - średnica zewnętrzna rury
- b. **L** - długość korpusu przepustnicy
- c. **L1** - długość mufy
- d. **s** - grubość ścianki
- e. **XX** - oznaczenie materiału w systemie Chemowent

* do przepustnic w zakresie średnic d75 – d400 dostępna jest dodatkowa opcja pokrętła - z regulacją płynną.



W zakresie średnic d75 - d400 istnieje możliwość modyfikacji przepustnicy pod napęd elektryczny.

W zakresie średnic d110 – d1250 możliwe jest wykonanie przepustnicy z uszczelką EPDM

d110 - d400

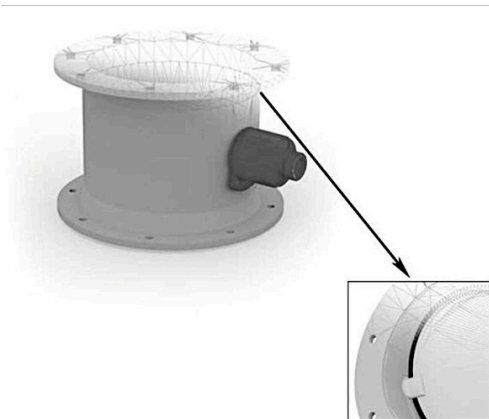

d450 - d1250

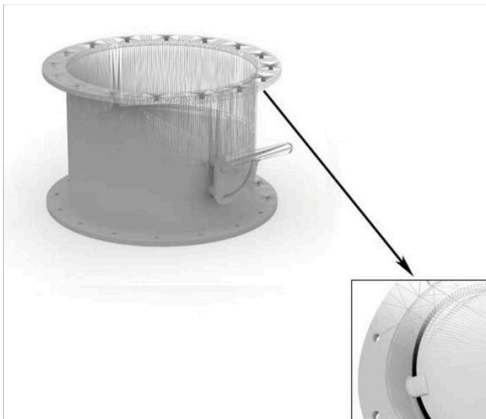

Współczynnik oporów miejscowych dla przepustnic wentylacyjnych zależy m.in. od stopnia otwarcia. Zależność tę prezentuje tabela:

ζ przy ustawieniach kłapy	0,5	1,5	4	11	33	120	250
	10°	20°	30°	40°	50°	60°	70°

1.18. Przepustnica regulacyjna pod napęd elektryczny, mufowa

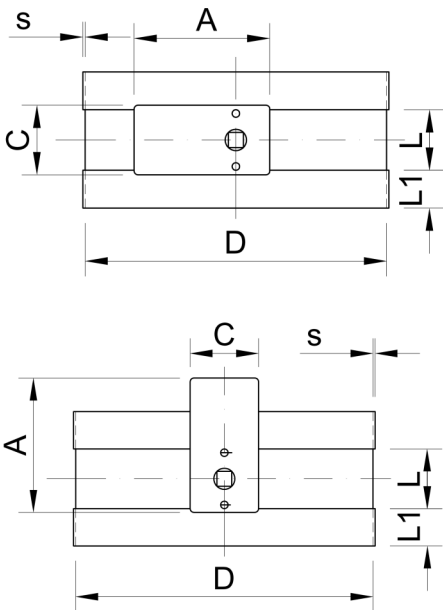
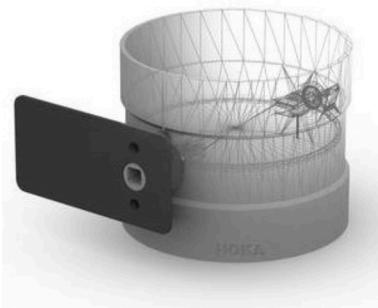

D	Nr kat.	L1	L	A	C	PVC	PPs/PP-EL
						-s/ PP/PE	
mm	---	mm	mm	mm	mm	mm	mm
50	XX.050.L.0071.E	35	60	180	92	3,0	3,0
63	XX.063.L.0071.E	35	60	180	92	3,0	3,0
75	XX.075.L.0071.E	35	60	180	92	3,0	3,0
90	XX.090.L.0071.E	35	60	180	92	3,0	3,0
110	XX.110.L.0071.E	40	75	180	92	3,0	3,0
125	XX.125.L.0071.E	40	70	180	92	3,0	3,0
140	XX.140.L.0071.E	40	70	180	92	3,0	3,0
160	XX.160.L.0071.E	40	70	180	92	3,0	4,0
180	XX.180.L.0071.E	50	70	180	92	3,0	4,0
200	XX.200.L.0071.E	50	70	180	92	3,0	4,0
225	XX.225.L.0071.E	50	70	180	92	3,0	4,0
250	XX.250.L.0071.E	50	70	180	92	3,0	4,0
280	XX.280.L.0071.E	50	70	180	92	3,0	4,0
315	XX.315.L.0071.E	50	70	180	92	3,0	4,0
355	XX.355.L.0071.E	50	75	180	92	4,0	4,0
400	XX.400.L.0071.E	50	80	180	92	4,0	4,0

Oznaczenia w tabeli:

- a. **D** - średnica zewnętrzna rury
- b. **L** - długość korpusu przepustnicy
- c. **L1** - długość mufy
- d. **A, C** - wymiary adaptera
- e. **s** - grubość ścianki
- f. **XX** - oznaczenie materiału w systemie Chemowent

Przepustnice w zakresie średnic d50-d400 wyposażane są w adaptery:

D1 - prostopadle do rurociągu

D2 - równoległe do rurociągu

Wymiar adaptera 180 x 92 mm.



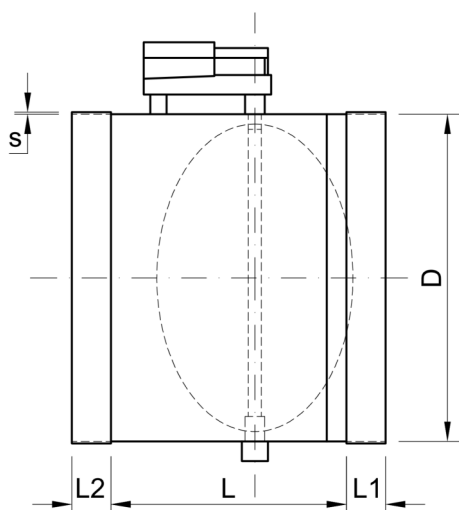

D	Nr kat.	L	L1	L2	PVC	PPs/PP-EL-s/ PP/PE
					s	
mm	---	mm	mm	mm	mm	mm
450	XX.450.L.0071.E	320	60	60	3,6	6,0
500	XX.500.L.0071.E	360	60	60	4,0	6,0
560	XX.560.L.0071.E	410	70	70	-	6,0
600	XX.600.L.0071.E	450	70	70	5,0	8,0
630	XX.630.L.0071.E	480	70	70	-	8,0
700	XX.700.L.0071.E	520	70	70	6,0	8,0
710	XX.710.L.0071.E	530	80	80	-	8,0
800	XX.800.L.0071.E	560	80	80	8,0	8,0
900	XX.900.L.0071.E	650	90	90	8,0	10,0
1000	XX.1000.L.0071.E	740	100	100	10,0	10,0
1200	XX.1200.L.0071.E	960	120	120	12,0	12,0
1250	XX.1250.L.0071.E	960	130	130	12,0	12,0

Oznaczenia w tabeli:

- a. **D** - średnica zewnętrzna rury
- b. **L** - długość korpusu przepustnicy
- c. **L1** - długość mufy
- d. **L2** - długość mufy nr 2
- e. **s** - grubość ścianki
- f. **XX** - oznaczenie materiału w systemie Chemowent

Współczynnik oporów miejscowych dla przepustnic wentylacyjnych zależy m.in. od stopnia otwarcia. Zależność tę prezentuje tabela:

ζ przy ustawieniach kłapy	0,5	1,5	4	11	33	120	250
	10°	20°	30°	40°	50°	60°	70°

1.19. Przepustnica regulacyjna pod napęd elektryczny, kołnierzowa

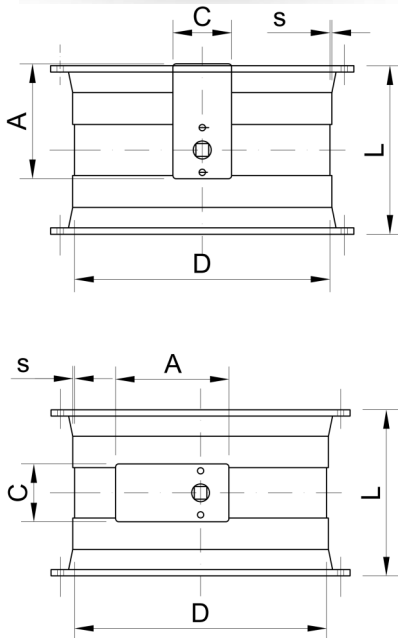

D	Nr kat.	L	A	C	PVC	PPs/PP-EL-s/ PP/PE
					s	
mm	---	mm	mm	mm	mm	mm
75	XX.075.L.0171.E	188	180	92	3,0	3,0
90	XX.090.L.0171.E	188	180	92	3,0	3,0
110	XX.110.L.0171.E	215	180	92	3,0	3,0
125	XX.125.L.0171.E	210	180	92	3,0	3,0
140	XX.140.L.0171.E	210	180	92	3,0	3,0
160	XX.160.L.0171.E	210	180	92	3,0	4,0
180	XX.180.L.0171.E	230	180	92	3,0	4,0
200	XX.200.L.0171.E	230	180	92	3,0	4,0
225	XX.225.L.0171.E	230	180	92	3,0	4,0
250	XX.250.L.0171.E	230	180	92	3,0	4,0
280	XX.280.L.0171.E	230	180	92	3,0	4,0
315	XX.315.L.0171.E	230	180	92	3,0	4,0
355	XX.355.L.0171.E	235	180	92	4,0	4,0
400	XX.400.L.0171.E	240	180	92	4,0	4,0

Oznaczenia w tabeli:

- a. **D** - średnica zewnętrzna rury
- b. **L** - długość korpusu przepustnicy
- c. **A, C** - wymiary adaptera
- d. **s** - grubość ścianki
- e. **XX** - oznaczenie materiału w systemie Chemowent

Przepustnice w zakresie średnic d75-d400 wyposażane są w adaptery:

D1 - prostopadle do rurociągu

D2 - równolegle do rurociągu

Wymiar adaptera 180 x 92 mm.

D1



D2



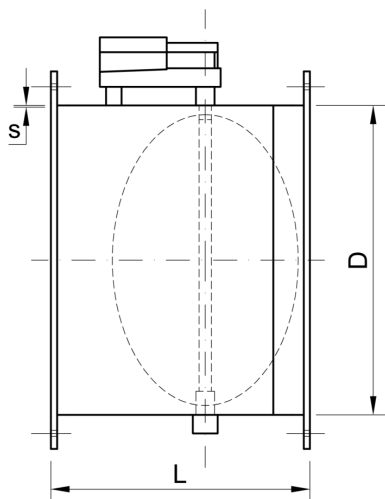

D	Nr kat.	L	PVC	PPs/PP-EL-s/ PP/PE
			s	
450	XX.450.L.0171.E	378	3,6	5,0
500	XX.500.L.0171.E	418	4,0	5,0
560	XX.560.L.0171.E	418	-	6,0
600	XX.600.L.0171.E	458	5,0	6,0
630	XX.630.L.0171.E	488	-	6,0
700	XX.700.L.0171.E	528	6,0	8,0
710	XX.710.L.0171.E	538	-	8,0
800	XX.800.L.0171.E	568	8,0	8,0
900	XX.900.L.0171.E	658	8,0	10,0
1000	XX.1000.L.0171.E	748	10,0	10,0
1200	XX.1200.L.0171.E	968	12,0	12,0
1250	XX.1250.L.0171.E	968	12,0	12,0

Oznaczenia w tabeli:

- a. **D** - średnica zewnętrzna rury
- b. **L** - długość korpusu przepustnicy
- c. **s** - grubość ścianki
- d. **XX** - oznaczenie materiału w systemie Chemowent

Współczynnik oporów miejscowych dla przepustnic wentylacyjnych zależy m.in. od stopnia otwarcia. Zależność tę prezentuje tabela:

ζ przy ustawieniach kłapy	0,5	1,5	4	11	33	120	250
	10°	20°	30°	40°	50°	60°	70°

1.20. Przepustnica regulacyjna z napędem pneumatycznym, mufowa

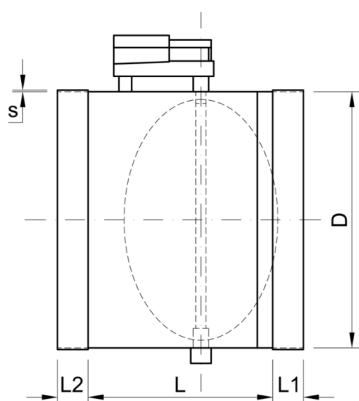

Oznaczenia w tabeli:

- a. **D** - średnica zewnętrzna rury
- b. **L** - długość korpusu przepustnicy
- c. **L1** - długość mufy
- d. **L2** - długość mufy nr 2
- e. **s** - grubość ścianki
- f. **XX** - oznaczenie materiału w systemie Chemowent

D	Nr kat.	PVC				PPs/PP-EL-s/ PP/PE			
		L1	L	L2	s	L1	L	L2	s
mm	---	mm	mm	mm	mm	mm	mm	mm	mm
110	XX.110.L.0071.P	40	244	35	2,5	40	247	40	3,0
125	XX.125.L.0071.P	40	244	35	2,5	40	247	40	3,0
140	XX.140.L.0071.P	40	244	35	2,5	40	247	40	3,0
160	XX.160.L.0071.P	40	273	35	2,5	40	276	40	3,0
180	XX.180.L.0071.P	40	273	35	2,5	40	276	40	3,5
200	XX.200.L.0071.P	40	273	35	2,5	40	276	40	3,5
225	XX.225.L.0071.P	40	306	35	2,5	50	300	50	3,5
250	XX.250.L.0071.P	31	315	35	2,5	26	314	26	3,5
280	XX.280.L.0071.P	41	315	45	2,5	36	314	36	3,5
315	XX.315.L.0071.P	40	316	45	2,5	36	314	36	4,0
355	XX.355.L.0071.P	41	329	45	3,0	38	332	38	5,0
400	XX.400.L.0071.P	41	329	45	3,0	38	372	38	5,0
450	XX.450.L.0071.P	60	320	60	3,6	60	320	60	6,0
500	XX.500.L.0071.P	60	360	60	4,0	60	360	60	6,0
560	XX.560.L.0071.P	-	-	-	-	70	410	70	6,0
600	XX.600.L.0071.P	70	450	70	5,0	70	450	70	8,0
630	XX.630.L.0071.P	-	-	-	-	70	480	70	8,0
700	XX.700.L.0071.P	70	520	70	6,0	70	520	70	8,0
710	XX.710.L.0071.P	-	-	-	-	80	530	80	8,0
800	XX.800.L.0071.P	80	560	80	8,0	80	560	80	8,0
900	XX.900.L.0071.P	90	650	90	8,0	90	650	90	10,0
1000	XX.1000.L.0071.P	100	740	100	10,0	100	740	100	10,0
1200	XX.1200.L.0071.P	120	960	120	12,0	120	960	120	12,0
1250	XX.1250.L.0071.P	130	960	130	12,0	130	960	130	12,0

Współczynnik oporów miejscowych dla przepustnic wentylacyjnych zależy m.in. od stopnia otwarcia. Zależność tę prezentuje tabela:

ζ przy ustawieniach kłapy	0,5	1,5	4	11	33	120	250
	10°	20°	30°	40°	50°	60°	70°

1.21. Przepustnica regulacyjna z napędem pneumatycznym, kołnierzowa

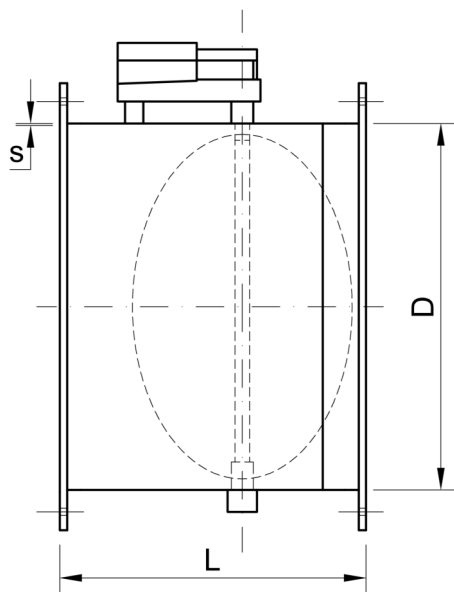

D	Nr kat.	L	PVC	PPs/PP-EL-s/ PP/PE
			s	
mm	---	mm	mm	mm
110	XX.110.L.0171.P.N	320	2,5	3,0
125	XX.125.L.0171.P.N	320	2,5	3,0
140	XX.140.L.0171.P.N	320	2,5	3,0
160	XX.160.L.0171.P.N	320	2,5	3,0
180	XX.180.L.0171.P.N	320	2,5	3,5
200	XX.200.L.0171.P.N	350	2,5	3,5
225	XX.225.L.0171.P.N	350	2,5	3,5
250	XX.250.L.0171.P.N	350	2,5	3,5
280	XX.280.L.0171.P.N	400	2,5	3,5
315	XX.315.L.0171.P.N	400	2,5	4,0
355	XX.355.L.0171.P.N	400	3,0	4,0
400	XX.400.L.0171.P.N	400	3,0	4,5
450	XX.450.L.0171.P.N	378	3,6	5,0
500	XX.500.L.0171.P.N	418	4,0	5,0
560	XX.560.L.0171.P.N	418	-	6,0
600	XX.600.L.0171.P.N	458	5,0	6,0
630	XX.630.L.0171.P.N	488	-	6,0
700	XX.700.L.0171.P.N	528	6,0	8,0
710	XX.710.L.0171.P.N	538	-	8,0
800	XX.800.L.0171.P.N	568	8,0	8,0
900	XX.900.L.0171.P.N	658	8,0	10,0
1000	XX.1000.L.0171.P.N	748	10,0	10,0
1200	XX.1200.L.0171.P.N	968	12,0	12,0
1250	XX.1250.L.0171.P.N	968	12,0	12,0

Oznaczenia w tabeli:

- a. **D** - średnica zewnętrzna rury
- b. **L** - długość korpusu przepustnicy
- c. **s** - grubość ścianki
- f. **XX** - oznaczenie materiału w systemie Chemowent

Współczynnik oporów miejscowych dla przepustnic wentylacyjnych zależy m.in. od stopnia otwarcia. Zależność tę prezentuje tabela:

ζ przy ustawieniach kłapy	0,5	1,5	4	11	33	120	250
	10°	20°	30°	40°	50°	60°	70°

1.22. Kłapa zwrotna do zabudowy pionowej - model 1

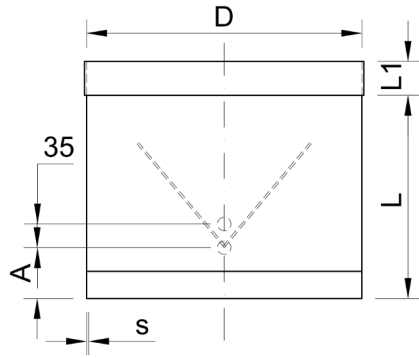
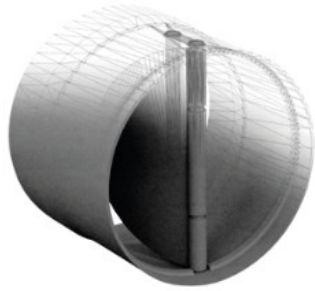

Oznaczenia w tabeli:

- a. **D** - średnica zewnętrzna rury
 - b. **L1** - długość mufy
 - c. **L** - wysokość kłapy
 - d. **s** - grubość ścianki
 - e. **XX** - oznaczenie materiału w systemie Chemowent
- * kłapa w wykonaniu z PP-EL-s dostępna od średnicy \varnothing 160 mm
 prędkość powietrza maks. 10 m/sek.

Współczynnik oporów miejscowych $[\zeta]$: 0,5

D	Nr kat.	L	L1	A	PVC	PPs	PP-EL-s	PP	PE
					s				
mm	---	mm	mm	mm	mm				
90	XX.090.L.4601	140	40	65	1,8	3,0	*	2,7	3,4
110	XX.110.L.4601	160	40	65	1,8	3,0	*	2,7	3,4
125	XX.125.L.4601	165	40	65	1,8	3,0	*	3,1	3,9
140	XX.140.L.4601	170	40	65	1,8	3,0	*	3,5	4,3
160	XX.160.L.4601	180	40	65	1,8	3,0	3,0	4,0	4,0
180	XX.180.L.4601	190	40	65	1,8	3,0	3,0	4,4	5,5
200	XX.200.L.4601	200	40	65	1,8	3,0	3,0	3,0	6,2
225	XX.225.L.4601	210	40	65	1,8	3,5	3,5	5,5	6,9
250	XX.250.L.4601	225	40	65	2,0	3,5	3,5	3,5	6,2
280	XX.280.L.4601	240	50	75	2,3	3,5	3,5	6,9	8,6
315	XX.315.L.4601	260	50	75	2,5	5,0	5,0	5,0	7,7
355	XX.355.L.4601	280	50	75	2,9	5,0	5,0	5,0	10,9
400	XX.400.L.4601	300	50	75	3,2	6,0	6,0	6,0	12,3
450	XX.450.L.4601	340	50	75	3,6	5,0	5,0	5,0	5,0
500	XX.500.L.4601	380	50	75	4,0	5,0	5,0	5,0	5,0
560	XX.560.L.4601	420	60	85	-	6,0	6,0	6,0	6,0
600	XX.600.L.4601	450	60	85	5,0	6,0	6,0	6,0	6,0
630	XX.630.L.4601	480	70	95	-	6,0	6,0	6,0	6,0
700	XX.700.L.4601	530	70	95	6,0	6,0	6,0	6,0	6,0
710	XX.710.L.4601	540	80	105	-	6,0	6,0	6,0	6,0
800	XX.800.L.4601	600	80	105	8,0	8,0	8,0	8,0	8,0
900	XX.900.L.4601	680	90	115	8,0	8,0	8,0	8,0	8,0
1000	XX.1000.L.4601	750	100	125	10,0	10,0	10,0	10,0	10,0
1200	XX.1200.L.4601	900	120	135	12,0	12,0	12,0	12,0	12,0
1250	XX.1250.L.4601	940	130	145	12,0	12,0	12,0	12,0	12,0

1.23. Kłapa zwrotna do zabudowy pionowej - model 2

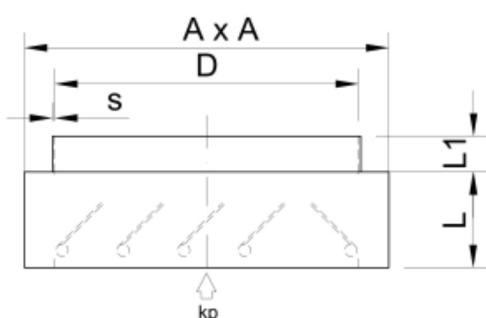
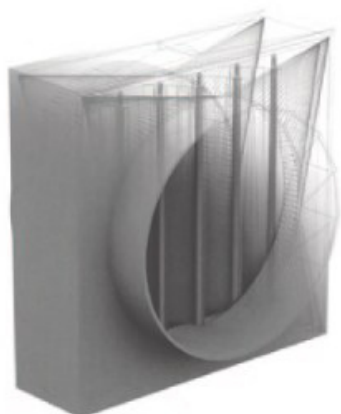

D	Nr kat.	L1	L	A/A	PVC	PPs/PP-EL
					s	
mm	---	mm	mm	mm	mm	mm
110	XX.110.L.4602	40	65	170*	5,0	5,0
125	XX.125.L.4602	40	65	170*	5,0	5,0
140	XX.140.L.4602	40	70	205	5,0	5,0
160	XX.160.L.4602	40	70	205	5,0	5,0
180	XX.180.L.4602	40	70	255	5,0	5,0
200	XX.200.L.4602	40	70	255	5,0	5,0
225	XX.225.L.4602	40	80	305	5,0	5,0
250	XX.250.L.4602	40	80	305	5,0	5,0
280	XX.280.L.4602	50	90	358	6,0	6,0
315	XX.315.L.4602	50	90	358	6,0	6,0
355	XX.355.L.4602	50	90	410	6,0	6,0
400	XX.400.L.4602	50	120	474	6,0	6,0
450	XX.450.L.4602	50	120	512	6,0	6,0
500	XX.500.L.4602	50	120	560	6,0	6,0
560	XX.560.L.4602	60	120	712	-	6,0
600	XX.600.L.4602	60	120	712	6,0	6,0
630	XX.630.L.4602	70	120	712	-	6,0

Oznaczenia w tabeli:

- D** - średnica zewnętrzna rury
- L1** - długość mufy
- L** - długość kłapy
- s** - grubość ścianki
- XX** - oznaczenie materiału w systemie Chemowent

* wymiar A/A dla kłap wykonanych z PP-EL-s = 205 mm

Lamele w kłapach ze wszystkich tworzyw wykonane są z PVC

prędkość powietrza maks. 10 m/sek.

Współczynnik oporów miejscowych [ζ]: 1,5

1.24. Kłapa zwrotna do zabudowy poziomej - model 3

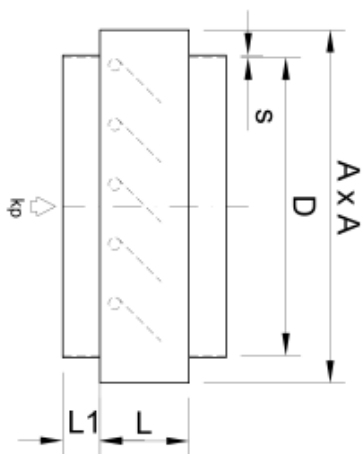
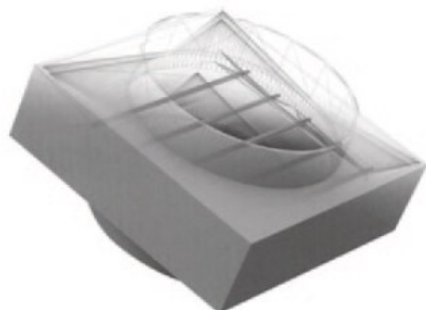

D	Nr kat.	L1	L	A/A	PVC	PPs/PP-EL-s/ PP/PE
					s	
mm	---	mm	mm	mm	mm	mm
110	XX.110.L.4603	40	65	170*	5,0	5,0
125	XX.125.L.4603	40	65	170*	5,0	5,0
140	XX.140.L.4603	40	70	205	5,0	5,0
160	XX.160.L.4603	40	70	205	5,0	5,0
180	XX.180.L.4603	40	70	255	5,0	5,0
200	XX.200.L.4603	40	70	255	5,0	5,0
225	XX.225.L.4603	40	80	305	5,0	5,0
250	XX.250.L.4603	40	80	305	5,0	5,0
280	XX.280.L.4603	50	90	358	6,0	6,0
315	XX.315.L.4603	50	90	358	6,0	6,0
355	XX.355.L.4603	50	90	410	6,0	6,0
400	XX.400.L.4603	50	120	474	6,0	6,0
450	XX.450.L.4603	50	120	512	6,0	6,0
500	XX.500.L.4603	50	120	560	6,0	6,0
560	XX.560.L.4603	60	120	712	-	6,0
600	XX.600.L.4603	60	120	712	6,0	6,0
630	XX.630.L.4603	70	120	712	-	6,0

Oznaczenia w tabeli:

- a. **D** - średnica zewnętrzna rury
 - b. **L1** - długość mufy
 - c. **L** - długość kłapy
 - d. **s** - grubość ścianki
 - e. **XX** - oznaczenie materiału w systemie Chemowent
PVC – 88; PPs – 36, PP-EL-s - 40; PP – 30; PE – 22
- * wymiar A/A dla kłap wykonanych z PP-EL-s = 205 mm

Lamele w kłapach ze wszystkich tworzyw wykonane są z PVC

prędkość powietrza maks. 10 m/sek.

Współczynnik oporów miejscowych [ζ]: 1,5

1.25. Króciec z siatką ochronną

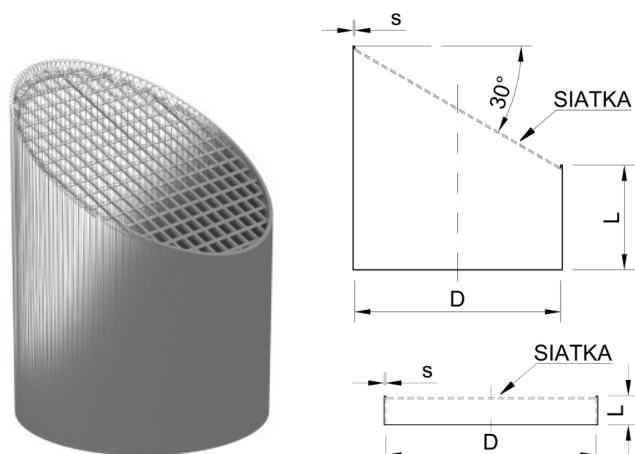

Oznaczenia w tabeli:

a. **D** - średnica zewnętrzna rury

b. **L** - wysokość króćca

c. **XX** - oznaczenie materiału w systemie Chemowent

Standardowo dostępna jest opcja bosa króćca.

Współczynnik oporów miejscowych [ζ]: 1,4

D	Nr kat.	króciec 30°					króciec 0°			
		L	PVC	PPs	PP-EL-s	PP	PE	L	PVC	PPs/PP-EL-
mm	---	mm	mm					mm	mm	
75	XX.075.L.6001	100	1,8	3,0	3,0	1,9	4,5	40	2,5	3,0
90	XX.090.L.6001	100	1,8	3,0	3,0	2,2	5,4	40	2,5	3,0
110	XX.110.L.6001	100	1,8	3,0	3,0	2,7	3,4	40	2,5	3,0
125	XX.125.L.6001	100	1,8	3,0	3,0	3,1	3,9	40	2,5	3,0
140	XX.140.L.6001	100	1,8	3,0	3,0	3,5	4,3	40	2,5	3,0
160	XX.160.L.6001	100	1,8	3,0	3,0	4,0	4,0	40	2,5	3,0
180	XX.180.L.6001	150	1,8	3,0	3,0	4,4	5,5	40	2,5	3,0
200	XX.200.L.6001	150	1,8	3,0	3,0	3,0	6,2	40	2,5	3,0
225	XX.225.L.6001	150	1,8	3,5	3,5	5,5	6,9	40	2,5	3,5
250	XX.250.L.6001	150	2,0	3,5	3,5	3,5	6,2	40	2,5	3,5
280	XX.280.L.6001	200	2,3	3,5	3,5	6,9	8,6	50	2,5	3,5
315	XX.315.L.6001	200	2,5	5,0	5,0	5,0	7,7	50	2,5	4,0
355	XX.355.L.6001	200	2,9	5,0	5,0	5,0	10,9	50	3,0	4,0
400	XX.400.L.6001	200	3,2	6,0	6,0	6,0	12,3	50	3,0	4,5
450	XX.450.L.6001	250	3,6	5,0	5,0	5,0	5,0	55	5,0	5,0
500	XX.500.L.6001	250	4,0	5,0	5,0	5,0	5,0	55	5,0	5,0
560	XX.560.L.6001	250	-	6,0	6,0	6,0	6,0	-	-	5,0
600	XX.600.L.6001	300	5,0	6,0	6,0	6,0	6,0	55	6,0	6,0
630	XX.630.L.6001	300	-	6,0	6,0	6,0	6,0	-	-	6,0
700	XX.700.L.6001	350	6,0	6,0	6,0	6,0	6,0	70	6,0	6,0
710	XX.710.L.6001	350	-	6,0	6,0	6,0	6,0	-	-	6,0
800	XX.800.L.6001	400	8,0	8,0	8,0	8,0	8,0	80	8,0	8,0
900	XX.900.L.6001	450	8,0	8,0	8,0	8,0	8,0	90	8,0	8,0
1000	XX.1000.L.6001	500	10,0	10,0	10,0	10,0	10,0	100	10,0	10,0
1200	XX.1200.L.6001	600	12,0	12,0	12,0	12,0	12,0	120	12,0	12,0
1250	XX.1250.L.6001	600	12,0	12,0	12,0	12,0	12,0	130	12,0	12,0

1.26. Przejście dachowe z tworzywa - nachylenie 0°

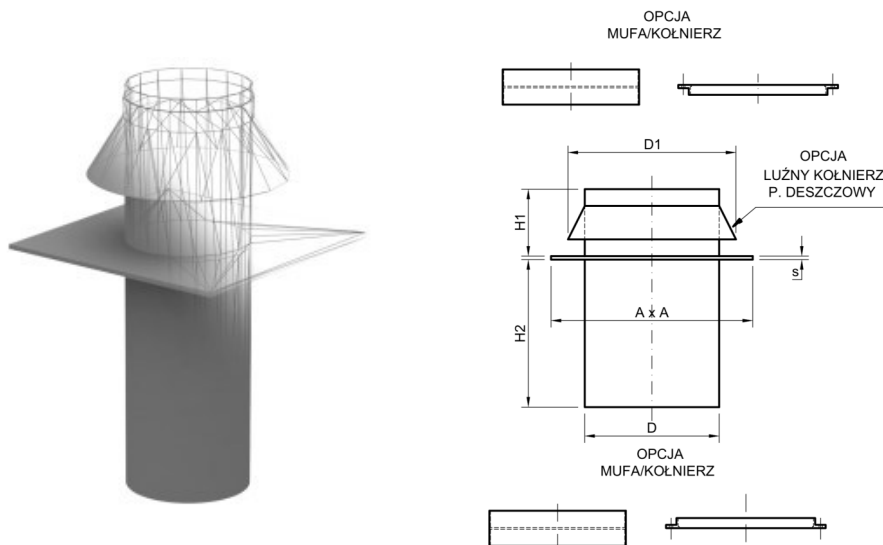

D	Nr kat.	D1	s	A/A	H1	H2	Grubość ścianki rury				
							PVC	PPs	PP-EL-	PP	PE
mm	---	mm	mm	mm	mm	mm	mm				
110	XX.110.L.3000.Y1Y2	200	8	350x350	250	400	1,8	3,0	3,0	2,7	3,4
125	XX.125.L.3000.Y1Y2	250	8	350x350	250	400	1,8	3,0	3,0	3,1	3,9
140	XX.140.L.3000.Y1Y2	250	8	350x350	250	400	1,8	3,0	3,0	3,5	4,3
160	XX.160.L.3000.Y1Y2	315	8	400x400	250	400	1,8	3,0	3,0	4,0	4,0
180	XX.180.L.3000.Y1Y2	315	8	400x400	250	400	1,8	3,0	3,0	4,4	5,5
200	XX.200.L.3000.Y1Y2	315	8	400x400	250	400	1,8	3,0	3,0	3,0	6,2
225	XX.225.L.3000.Y1Y2	400	10	450x450	250	400	1,8	3,5	3,5	5,5	6,9
250	XX.250.L.3000.Y1Y2	450	10	450x450	250	400	2,0	3,5	3,5	3,5	6,2
280	XX.280.L.3000.Y1Y2	500	10	500x500	250	400	2,3	3,5	3,5	6,9	8,6
315	XX.315.L.3000.Y1Y2	500	10	500x500	250	400	2,5	5,0	5,0	5,0	7,7
355	XX.355.L.3000.Y1Y2	500	10	550x550	250	400	2,9	5,0	5,0	5,0	10,9
400	XX.400.L.3000.Y1Y2	500	10	600x600	250	400	3,2	6,0	6,0	6,0	12,3
450	XX.450.L.3000.Y1Y2	600	10	750x750	250	400	3,6	6,0	6,0	6,0	6,0
500	XX.500.L.3000.Y1Y2	700	10	800x800	250	400	4,0	6,0	6,0	6,0	6,0
560	XX.560.L.3000.Y1Y2	800	10	860x860	250	400	-	6,0	6,0	6,0	6,0
600	XX.600.L.3000.Y1Y2	800	10	900x900	250	400	5,0	6,0	6,0	6,0	6,0
630	XX.630.L.3000.Y1Y2	800	10	930x930	250	400	-	6,0	6,0	6,0	6,0
700	XX.700.L.3000.Y1Y2	900	12	1100x1100	250	400	6,0	6,0	6,0	6,0	6,0
710	XX.710.L.3000.Y1Y2	900	12	1100x1100	250	400	-	6,0	6,0	6,0	6,0
800	XX.800.L.3000.Y1Y2	1000	12	1200x1200	250	400	8,0	8,0	8,0	8,0	8,0
900	XX.900.L.3000.Y1Y2	1200	12	1300x1300	250	400	8,0	8,0	8,0	8,0	8,0
1000	XX.1000.L.3000.Y1Y2	1200	12	1400x1400	250	400	10,0	10,0	10,0	10,0	10,0
1200	XX.1200.L.3000.Y1Y2	1400	12	1600x1600	250	400	12,0	12,0	12,0	12,0	12,0
1250	XX.1250.L.3000.Y1Y2	1400	12	1650x1650	250	400	12,0	12,0	12,0	12,0	12,0

1.27. Przejście dachowe z tworzywa - nachylenie 1-22°

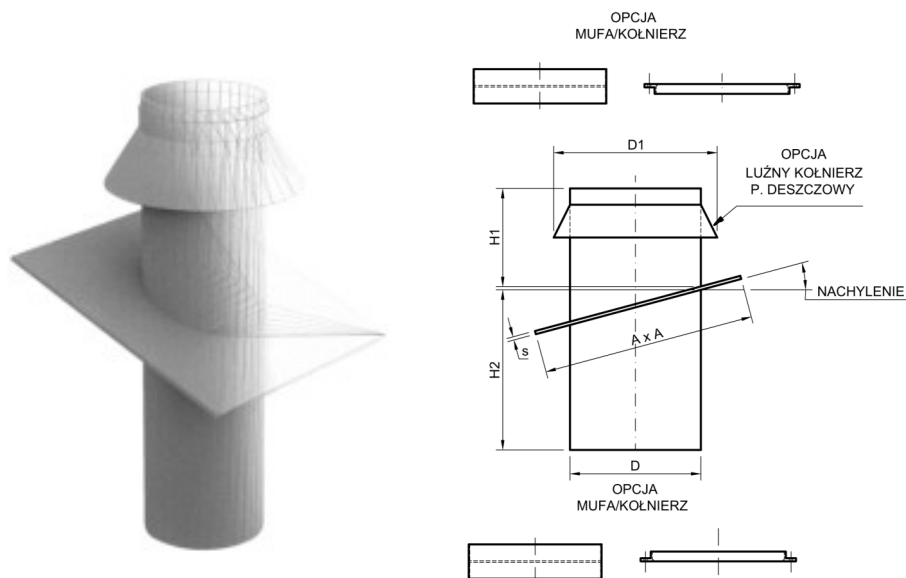

D	Nr kat.	D1	s	A/A	H1	H2	Grubość ścianki rury				
							PVC	PPs	PP-EL-s	PP	PE
mm	---	mm	mm	mm	mm	mm	mm				
110	XX.110.L.3122.Y1Y2	200	8	400x400	300	430	1,8	3,0	3,0	2,7	3,4
125	XX.125.L.3122.Y1Y2	250	8	400x400	300	430	1,8	3,0	3,0	3,1	3,9
140	XX.140.L.3122.Y1Y2	250	8	400x400	300	435	1,8	3,0	3,0	3,5	4,3
160	XX.160.L.3122.Y1Y2	315	8	450x450	300	440	1,8	3,0	3,0	4,0	4,0
180	XX.180.L.3122.Y1Y2	315	8	450x450	300	445	1,8	3,0	3,0	4,4	5,5
200	XX.200.L.3122.Y1Y2	315	8	450x450	300	450	1,8	3,0	3,0	3,0	6,2
225	XX.225.L.3122.Y1Y2	400	10	500x500	300	455	1,8	3,5	3,5	5,5	6,9
250	XX.250.L.3122.Y1Y2	450	10	500x500	300	460	2,0	3,5	3,5	3,5	6,2
280	XX.280.L.3122.Y1Y2	500	10	550x550	300	470	2,3	3,5	3,5	6,9	8,6
315	XX.315.L.3122.Y1Y2	500	10	550x550	300	480	2,5	5,0	5,0	5,0	7,7
355	XX.355.L.3122.Y1Y2	500	10	600x600	300	490	2,9	5,0	5,0	5,0	10,9
400	XX.400.L.3122.Y1Y2	500	10	650x650	300	500	3,2	6,0	6,0	6,0	12,3
450	XX.450.L.3122.Y1Y2	600	10	800x800	300	550	3,6	6,0	6,0	6,0	6,0
500	XX.500.L.3122.Y1Y2	700	10	850x850	300	550	4,0	6,0	6,0	6,0	6,0
560	XX.560.L.3122.Y1Y2	800	10	910x910	300	600	-	6,0	6,0	6,0	6,0
600	XX.600.L.3122.Y1Y2	800	10	950x950	300	600	5,0	6,0	6,0	6,0	6,0
630	XX.630.L.3122.Y1Y2	800	10	1000x1000	300	600	-	6,0	6,0	6,0	6,0
700	XX.700.L.3122.Y1Y2	900	12	1200x1200	300	650	6,0	6,0	6,0	6,0	6,0
710	XX.710.L.3122.Y1Y2	900	12	1200x1200	300	650	-	6,0	6,0	6,0	6,0
800	XX.800.L.3122.Y1Y2	1000	12	1300x1300	300	700	8,0	8,0	8,0	8,0	8,0
900	XX.900.L.3122.Y1Y2	1200	12	1400x1400	300	750	8,0	8,0	8,0	8,0	8,0
1000	XX.1000.L.3122.Y1Y2	1200	12	1500x1500	300	800	10,0	10,0	10,0	10,0	10,0
1200	XX.1200.L.3122.Y1Y2	1400	12	1700x1700	300	850	12,0	12,0	12,0	12,0	12,0
1250	XX.1250.L.3122.Y1Y2	1400	12	1700x1700	300	850	12,0	12,0	12,0	12,0	12,0

1.28. Przejście dachowe z tworzywa - nachylenie 23-45°

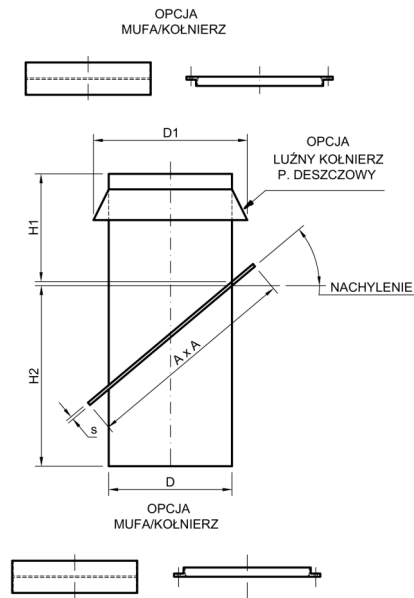
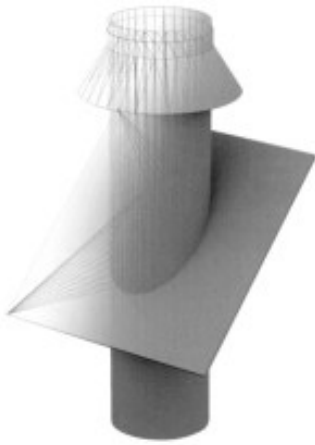

D	Nr kat.	D1	s	A/A	H1	H2	Grubość ścianki rury				
							PVC	PPs	PP-	PP	PE
mm	---	mm	mm	mm	mm	mm	mm				
110	XX.110.L.3345.Y1Y2	200	8	450x450	350	450	1,8	3,0	3,0	2,7	3,4
125	XX.125.L.3345.Y1Y2	250	8	450x450	350	460	1,8	3,0	3,0	3,1	3,9
140	XX.140.L.3345.Y1Y2	250	8	450x450	350	470	1,8	3,0	3,0	3,5	4,3
160	XX.160.L.3345.Y1Y2	315	8	500x500	350	480	1,8	3,0	3,0	4,0	4,0
180	XX.180.L.3345.Y1Y2	315	8	500x500	350	490	1,8	3,0	3,0	4,4	5,5
200	XX.200.L.3345.Y1Y2	315	8	500x500	350	500	1,8	3,0	3,0	3,0	6,2
225	XX.225.L.3345.Y1Y2	400	10	550x550	350	510	1,8	3,5	3,5	5,5	6,9
250	XX.250.L.3345.Y1Y2	450	10	550x550	350	525	2,0	3,5	3,5	3,5	6,2
280	XX.280.L.3345.Y1Y2	500	10	600x600	350	540	2,3	3,5	3,5	6,9	8,6
315	XX.315.L.3345.Y1Y2	500	10	600x600	350	550	2,5	5,0	5,0	5,0	7,7
355	XX.355.L.3345.Y1Y2	500	10	650x650	350	570	2,9	5,0	5,0	5,0	10,9
400	XX.400.L.3345.Y1Y2	500	10	700x700	350	600	3,2	6,0	6,0	6,0	12,3
450	XX.450.L.3345.Y1Y2	600	10	1050x1050	350	700	3,6	6,0	6,0	6,0	6,0
500	XX.500.L.3345.Y1Y2	700	10	1100x1100	350	800	4,0	6,0	6,0	6,0	6,0
560	XX.560.L.3345.Y1Y2	800	10	1160x1160	350	900	-	6,0	6,0	6,0	6,0
600	XX.600.L.3345.Y1Y2	800	10	1200x1200	350	900	5,0	6,0	6,0	6,0	6,0
630	XX.630.L.3345.Y1Y2	800	10	1230x1230	350	950	-	6,0	6,0	6,0	6,0
700	XX.700.L.3345.Y1Y2	900	12	1400x1400	350	1050	6,0	6,0	6,0	6,0	6,0
710	XX.710.L.3345.Y1Y2	900	12	1400x1400	350	1050	-	6,0	6,0	6,0	6,0
800	XX.800.L.3345.Y1Y2	1000	12	1600x1600	350	1150	8,0	8,0	8,0	8,0	8,0
900	XX.900.L.3345.Y1Y2	1200	12	1750x1750	350	1250	8,0	8,0	8,0	8,0	8,0
1000	XX.1000.L.3345.Y1Y2	1200	12	1900x1900	350	1350	10,0	10,0	10,0	10,0	10,0
1200	XX.1200.L.3345.Y1Y2	1400	12	2150x2150	350	1650	12,0	12,0	12,0	12,0	12,0
1250	XX.1250.L.3345.Y1Y2	1400	12	2200x2200	350	1650	12,0	12,0	12,0	12,0	12,0

Oznaczenia w tabelach przejść dachowych 0°, 1-22°, 23-45°

- a. **D** - średnica zewnętrzna rury
- b. **D1** - średnica kołnierza przeciwdeszczowego
- c. **s** - grubość płyty
- d. **XX** - oznaczenie materiału w systemie Chemowent
- e. **Y1** - wybór wariantu: **M** - opcja mufowa; **K** - opcja kołnierzowa, **LK** - luźny kołnierz przeciwdeszczowy
- f. **Y2** - wybór wariantu: **M** - opcja mufowa; **K** - opcja kołnierzowa, **LK** - luźny kołnierz przeciwdeszczowy

Przedłużenie dachu ze spadkiem NIE jest regulowane na miejscu!

Podczas zamawiania należy określić kąt nachylenia dachu.

1.29. Osłona przeciwdeszczowa

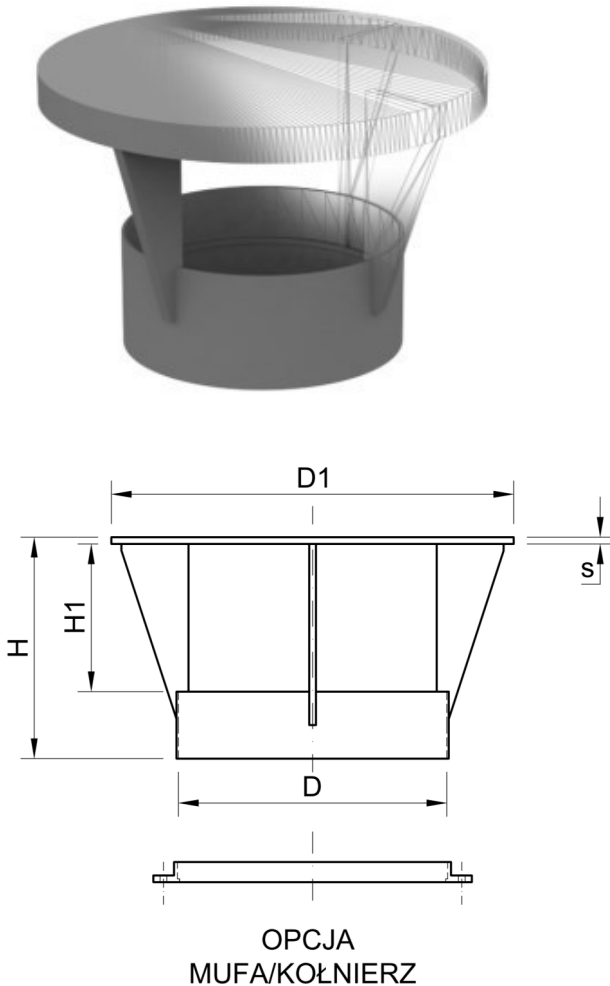

D	Nr kat.	D1	s	H	H1
mm	---	mm	mm	mm	mm
75	XX.075.L.400Y	225	8	165	55
90	XX.090.L.400Y	225	8	165	55
110	XX.110.L.400Y	225	8	165	55
125	XX.125.L.400Y	225	8	175	65
140	XX.140.L.400Y	250	8	180	70
160	XX.160.L.400Y	250	8	190	80
180	XX.180.L.400Y	280	8	200	90
200	XX.200.L.400Y	315	8	210	100
225	XX.225.L.400Y	355	8	225	115
250	XX.250.L.400Y	400	8	235	125
280	XX.280.L.400Y	450	10	270	140
315	XX.315.L.400Y	500	10	290	160
355	XX.355.L.400Y	550	10	300	170
400	XX.400.L.400Y	600	10	330	200
450	XX.450.L.400Y	650	10	350	225
500	XX.500.L.400Y	700	10	380	250
560*	XX.560.L.400Y	750	10	410	280
600	XX.600.L.400Y	800	10	430	300
630*	XX.630.L.400Y	850	10	440	315
700	XX.700.L.400Y	900	10	510	350
710*	XX.710.L.400Y	900	10	530	355
800	XX.800.L.400Y	1000	10	580	400
900	XX.900.L.400Y	1100	10	650	450
1000	XX.1000.L.400Y	1200	12	720	500
1200	XX.1200.L.400Y	1400	12	860	600
1250	XX.1250.L.400Y	1450	12	910	625

Oznaczenia w tabeli:

- a. **D** - średnica zewnętrzna rury
 - b. **D1** - średnica daszka przeciwdeszczowego
 - c. **XX** - oznaczenie materiału w systemie Chemowent
 - d. **Y** - wybór wariantu: **M** - opcja mufowa; **K** - opcja kołnierzowa
- * w tych średnicach nie są produkowane osłony z tworzywa PVC

Współczynnik oporów miejscowych [ζ]: 1,5

1.30. Wyrzutnia dachowa - deflektor

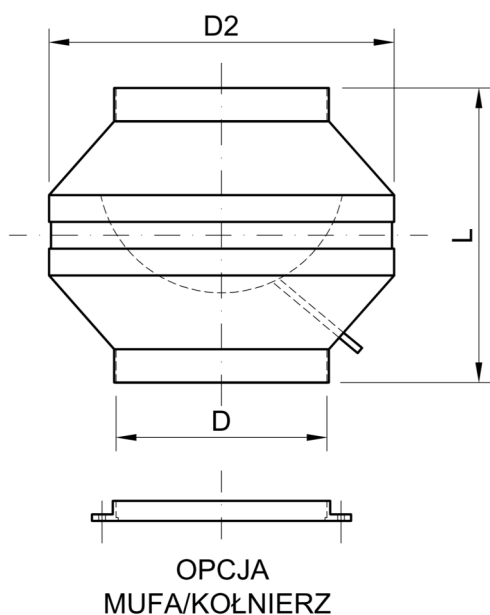
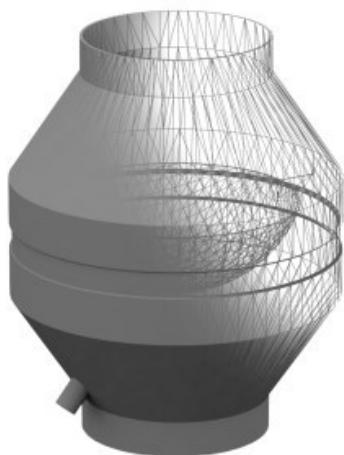

D	Nr kat.	D2	L
mm	---	mm	mm
110	XX.110.L.00YY	206	290
125	XX.125.L.00YY	256	340
140	XX.140.L.00YY	256	320
160	XX.160.L.00YY	321	410
180	XX.180.L.00YY	321	380
200	XX.200.L.00YY	361	410
225	XX.225.L.00YY	408	430
250	XX.250.L.00YY	458	470
280	XX.280.L.00YY	508	520
315	XX.315.L.00YY	508	440

od średnicy Ø355 mm konstrukcja prostokątna

Oznaczenia w tabeli:

- a. **D** - średnica zewnętrzna rury
- b. **L** - wysokość deflektora
- c. **XX** - oznaczenie materiału w systemie Chemowent
- d. **YY** - wybór wariantu: **M** - opcja mufowa; **K** - opcja kołnierzowa

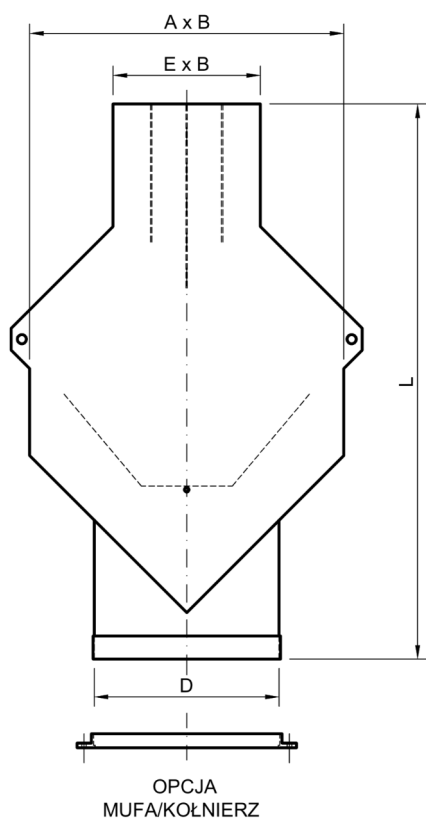
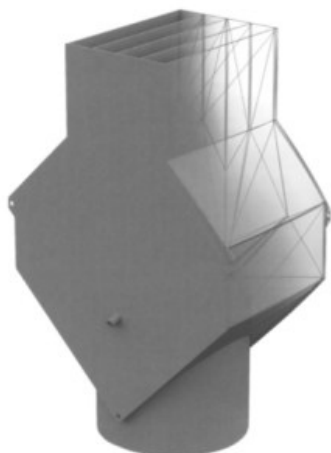

D	Nr kat.	L	A (x B)	E (x B)
mm	---	mm	mm	mm
355	XX.355.L.00YY	1100	600x405	280x405
400	XX.400.L.00YY	1200	675x450	310x450
450	XX.450.L.00YY	1320	760x500	350x500
500	XX.500.L.00YY	1440	840x550	390x550
560*	XX.560.L.00YY	1570	920x610	425x610
600	XX.600.L.00YY	1690	1005x650	465x650
630*	XX.630.L.00YY	1820	1090x680	500x680
700	XX.700.L.00YY	1940	1170x750	540x750
710*	XX.710.L.00YY	2070	1255x760	575x760
800	XX.800.L.00YY	2190	1335x850	615x850
900	XX.900.L.00YY	2430	1500x950	690x950
1000	XX.1000.L.00YY	2680	1670x1080	765x1080
1200	XX.1200.L.00YY	3180	2000x1280	915x1280
1250	XX.1250.L.00YY	3300	2080x1330	950x1330

Oznaczenia w tabeli:

- a. **D** - średnica zewnętrzna rury
 - b. **L** - wysokość deflektora
 - c. **XX** - oznaczenie materiału w systemie Chemowent
 - d. **YY** - wybór wariantu: **M** - opcja mufowa; **K** - opcja kołnierzowa
- * w tych średnicach nie są produkowane deflektory z tworzywa PVC
 Deflektor prostokątny od góry zabezpieczany jest siatką ochronną

1.31. Wywietrzak dachowy cylindryczny



D	Nr kat.	D₁	H	L
mm	---	mm	mm	mm
160	XX.160.L.990Y	315	200	300
200	XX.200.L.990Y	400	250	350
225	XX.225.L.990Y	450	280	430
250	XX.250.L.990Y	500	315	465
280	XX.280.L.990Y	560	350	500
315	XX.315.L.990Y	630	400	550
355	XX.355.L.990Y	710	445	595
400	XX.400.L.990Y	800	500	700
450	XX.450.L.990Y	900	560	760
500	XX.500.L.990Y	1000	625	825
600	XX.600.L.990Y	1200	750	950
700	XX.700.L.990Y	1400	875	1175
800	XX.800.L.990Y	1600	1000	1300

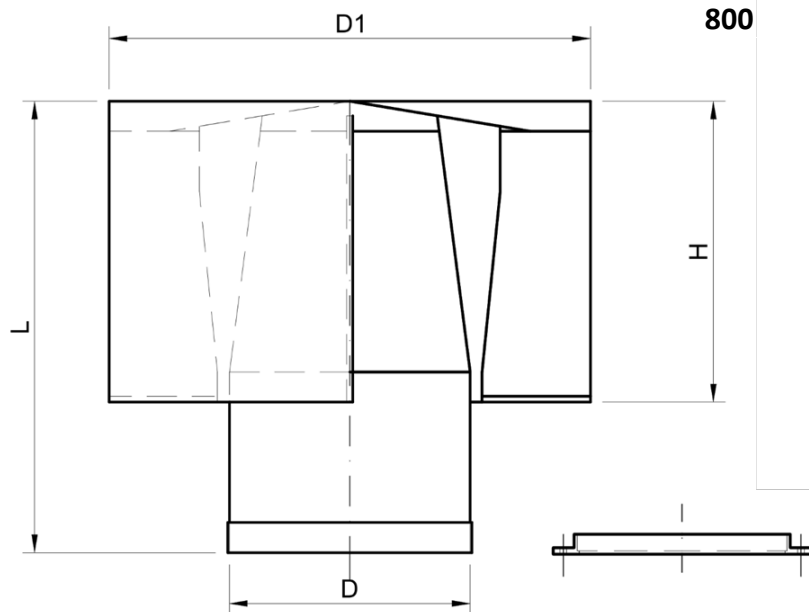

OPCJA
MUFA/KOŁNIERZ

Oznaczenia w tabeli:

- a. **D** - średnica zewnętrzna rury
- b. **D₁** - średnica cylindra
- c. **H** - wysokość cylindra
- d. **L** - wysokość wywietrzaka
- e. **XX** - oznaczenie materiału w systemie Chemowent
- f. **Y** - wybór wariantu: **M** - opcja mufowa; **K** - opcja kołnierzowa

Wykonanie z tworzywa **PVC** możliwe na indywidualne zapytanie

1.32. Podstawa dachowa pod wentylator

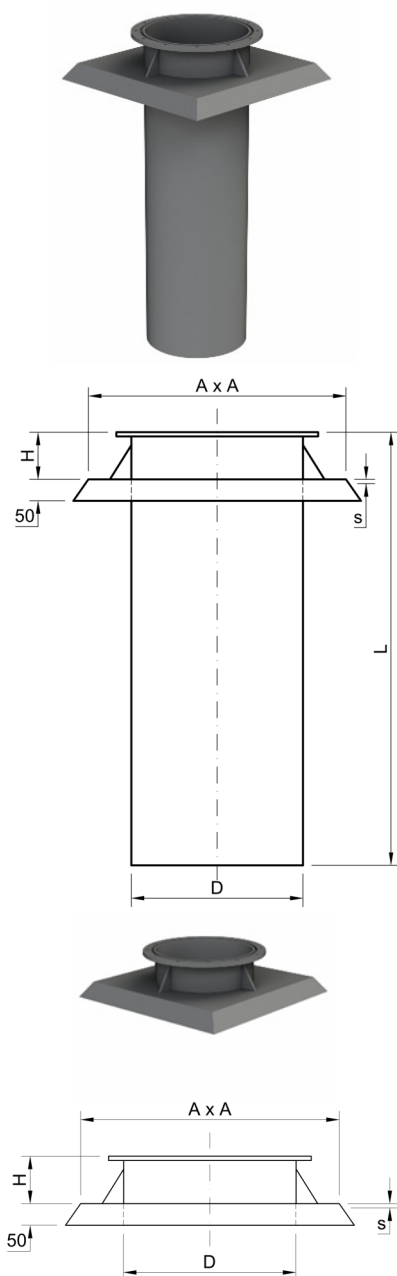

D	Nr kat.	H	A x A	L	s
mm	---	mm	mm	mm	mm
110	XX.110.L.3100.Y	100	350 x 350	1000	8
125	XX.125.L.3100.Y	100	350 x 350	1000	8
140	XX.140.L.3100.Y	100	350 x 350	1000	8
160	XX.160.L.3100.Y	100	400 x 400	1000	8
180	XX.180.L.3100.Y	100	400 x 400	1000	8
200	XX.200.L.3100.Y	100	400 x 400	1000	8
225	XX.225.L.3100.Y	100	450 x 450	1000	10
250	XX.250.L.3100.Y	100	450 x 450	1000	10
280	XX.280.L.3100.Y	100	500 x 500	1000	10
315	XX.315.L.3100.Y	100	500 x 500	1000	10
355	XX.355.L.3100.Y	100	500 x 500	1000	10
400	XX.400.L.3100.Y	100	600 x 600	1000	10
450	XX.450.L.3100.Y	100	750 x 750	1000	10
500	XX.500.L.3100.Y	100	800 x 800	1000	10
560*	XX.560.L.3100.Y	100	860 x 860	1000	10
600	XX.600.L.3100.Y	100	900 x 900	1000	10
630*	XX.630.L.3100.Y	100	930 x 930	1000	10
700*	XX.700.L.3100.Y	100	1100 x 1100	1000	12
710*	XX.710.L.3100.Y	100	1100 x 1100	1000	12
800*	XX.800.L.3100.Y	100	1200 x 1200	1000	12
900*	XX.900.L.3100.Y	100	1300 x 1300	1000	12
1000*	XX.1000.L.3100.Y	100	1400 x 1400	1000	12
1200*	XX.1200.L.3100.Y	100	1600 x 1600	1000	12
1250*	XX.1250.L.3100.Y	100	1650 x 1650	1000	12

Oznaczenia w tabeli:

- a. **D** - średnica zewnętrzna rury
- b. **XX** - oznaczenie materiału w systemie Chemowent
- c. **Y** - wybór wariantu: **BI** lub **BII**

* w tych średnicach nie są produkowane podstawy z tworzywa PVC

1.33. Zaślepka z tworzywa

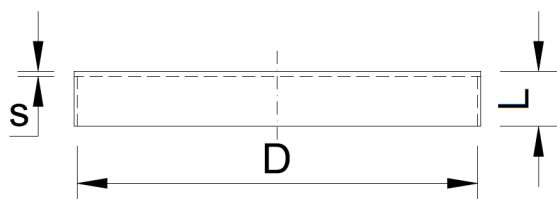
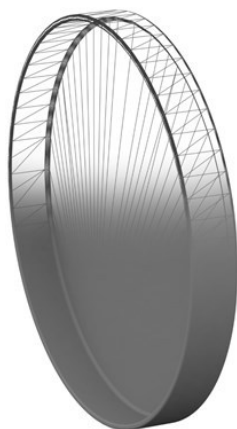

D	Nr kat.	L	s
mm	---	mm	mm
50	XX.050.L.0008	45	3
63	XX.063.L.0008	45	3
75	XX.075.L.0008	40	3
90	XX.090.L.0008	40	3
110	XX.110.L.0008	40	3
125	XX.125.L.0008	40	3
140	XX.140.L.0008	40	3
160	XX.160.L.0008	40	3
180	XX.180.L.0008	40	3
200	XX.200.L.0008	40	3
225	XX.225.L.0008	40	3
250	XX.250.L.0008	40	3
280	XX.280.L.0008	50	3
315	XX.315.L.0008	50	3
355	XX.355.L.0008	50	3
400	XX.400.L.0008	50	3
450	XX.450.L.0008	60	6
500	XX.500.L.0008	60	6
560*	XX.560.L.0008	60	6
600	XX.600.L.0008	60	6
630*	XX.630.L.0008	60	6
700	XX.700.L.0008	75	8
710*	XX.710.L.0008	85	8
800	XX.800.L.0008	85	8
900	XX.900.L.0008	95	8
1000	XX.1000.L.0008	105	10
1200	XX.1200.L.0008	125	12
1250	XX.1250.L.0008	135	12

Oznaczenia w tabeli:

- a. **D** - średnica zewnętrzna rury
- b. **L** - wysokość zaślepki
- c. **S** - grubość ścianki
- d. **XX** - oznaczenie materiału w systemie Chemowent

* w tych średnicach nie są produkowane zaślepki z tworzywa PVC

1.34. Kratka z regulowanymi lamelami PVC

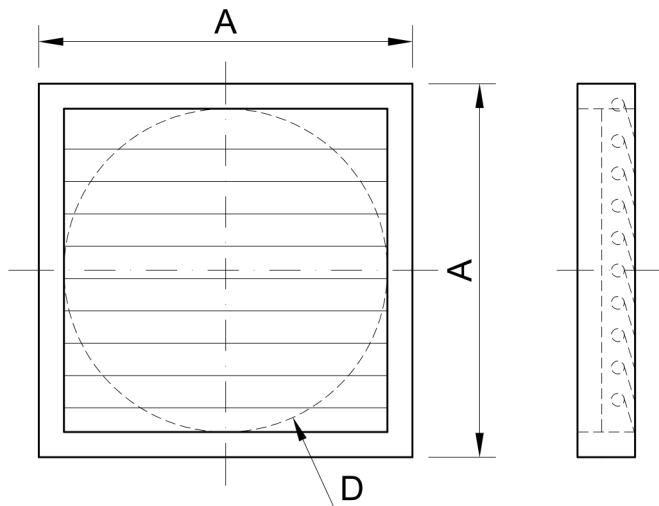

D	Nr kat.	A
mm	---	mm
110	88.110.L.0120	160
125	88.125.L.0120	160
140	88.140.L.0150	194
160	88.160.L.0150	194
180	88.180.L.0200	244
200	88.200.L.0200	244
225	88.225.L.0250	294
250	88.250.L.0250	294
280	88.280.L.0300	347
315	88.315.L.0300	347
355	88.355.L.0350	397
400	88.400.L.0400	462
450	88.450.L.0450	501
500	88.500.L.0500	549
600	88.600.L.0650	696

Strata ciśnienia, Vmax = 10 m/s		
d110-d200	100 m ³ /h	7-9 Pa
	1100 m ³ /h	60-70 Pa
d225-d315	100 m ³ /h	5 Pa
	1000 m ³ /h	18-28 Pa
	2800 m ³ /h	30-60 Pa
d225-d315	100 m ³ /h	3-5 Pa
	1000 m ³ /h	10-15 Pa
	4500 m ³ /h	20-28 Pa

Oznaczenia w tabeli:

a. D - średnica zewnętrzna rury

Kratka wraz z lamelami wykonana jest z szarego PVC; można ją też wykonać z PVC w kolorze białym

Maksymalna prędkość przepływu 10 m/s

1.35. Trójnik rewizyjny

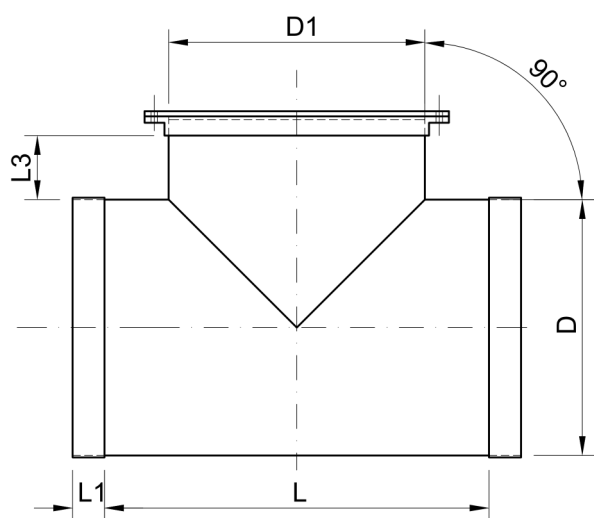
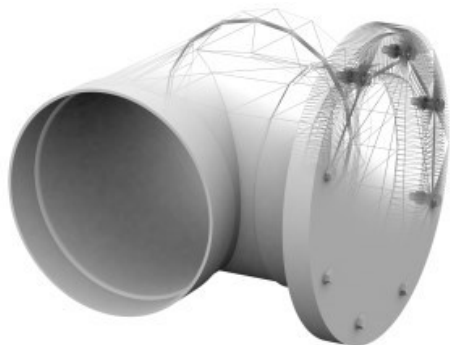

D	Nr kat.	D1	L	L1
mm	---	mm	mm	mm
110	XX.110.TR.0110	110	140	40
125	XX.125.TR.0125	125	155	40
140	XX.140.TR.0140	140	170	40
160	XX.160.TR.0160	160	190	40
180	XX.180.TR.0180	180	210	40
200	XX.200.TR.0200	200	230	40
225	XX.225.TR.0225	225	270	40
250	XX.250.TR.0250	250	280	40
280	XX.280.TR.0280	280	320	50
315	XX.315.TR.0315	315	345	50
355	XX.355.TR.0355	355	350	50
400	XX.400.TR.0400	400	350	50
450	XX.450.TR.0250	250	350	50
500	XX.500.TR.0315	315	415	50
560*	XX.560.TR.0315	315	415	60
600	XX.600.TR.0315	315	515	60
630*	XX.630.TR.0315	315	515	70
700	XX.700.TR.0315	315	515	70
710*	XX.710.TR.0315	315	515	80
800	XX.800.TR.0400	400	600	80
900	XX.900.TR.0400	400	600	90
1000	XX.1000.TR.0400	400	700	100
1200	XX.1200.TR.0400	400	700	120
1250	XX.1250.TR.0400	400	700	130

Oznaczenia w tabeli:

- a. **D** - średnica zewnętrzna rury
- b. **D1** - średnica króćca rewizyjnego
- c. **L** - długość trójnika
- d. **L1** - długość mufy
- e. **XX** - oznaczenie materiału w systemie Chemowent

* w tych średnicach nie są produkowane trójniki rewizyjne z tworzywa PVC

Inne średnice króćca rewizyjnego **D1** na zapytanie; max **D1** = **D**

1.36. Króciec rewizyjny

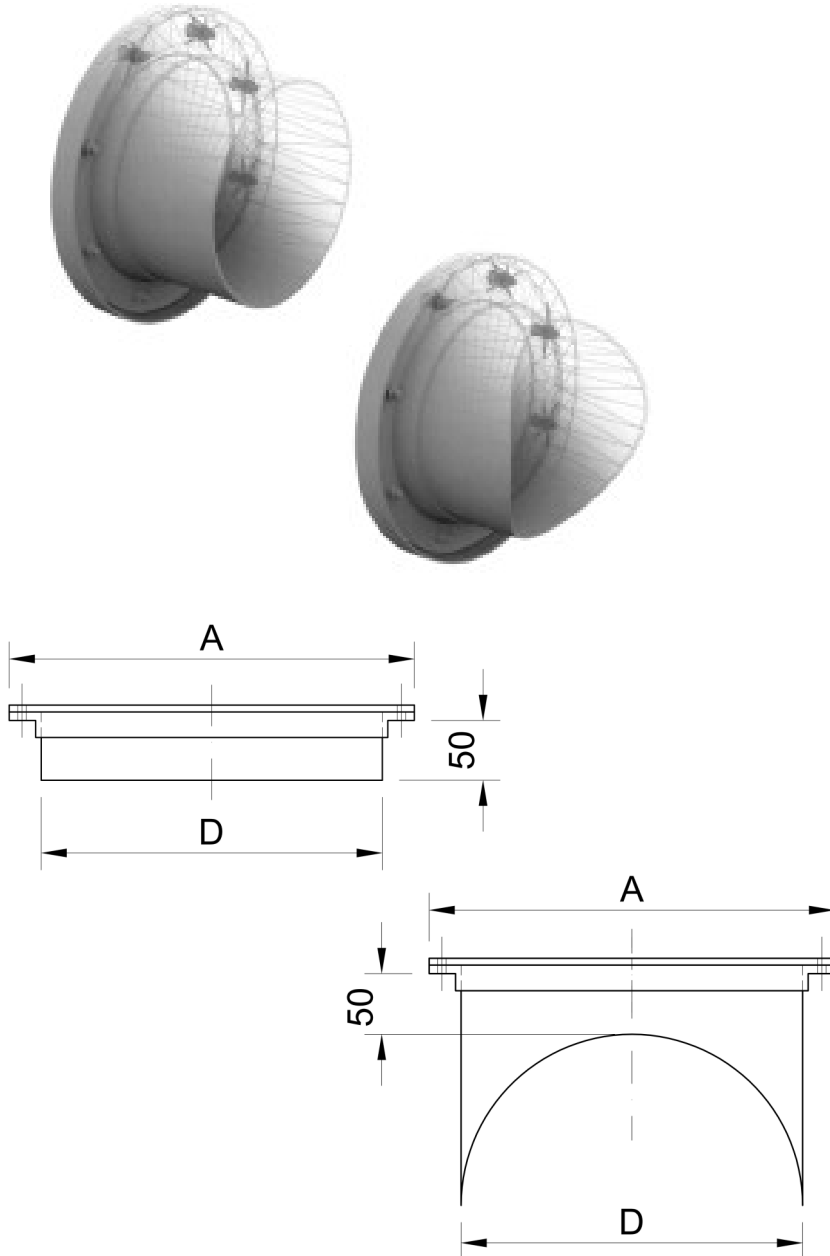

D	Nr kat.	A
mm	---	mm
110	XX.110.B.0000	170
125	XX.125.B.0000	185
140	XX.140.B.0000	200
160	XX.160.B.0000	230
180	XX.180.B.0000	250
200	XX.200.B.0000	270
225	XX.225.B.0000	295
250	XX.250.B.0000	320
280	XX.280.B.0000	355
315	XX.315.B.0000	395
355	XX.355.B.0000	435
400	XX.400.B.0000	475
450	XX.450.B.0000	560
500	XX.500.B.0000	610
560*	XX.560.B.0000	660
600	XX.600.B.0000	710
630*	XX.630.B.0000	760
700	XX.700.B.0000	810
710*	XX.710.B.0000	810
800	XX.800.B.0000	916
900	XX.900.B.0000	1016
1000	XX.1000.B.0000	1116
1100	XX.1100.B.0000	1320
1250	XX.1250.B.0000	1370

Oznaczenia w tabeli:

a. **D** - średnica zewnętrzna rury

b. **XX** - oznaczenie materiału w systemie Chemowent

* w tych średnicach nie są produkowane trójniki rewizyjne z tworzywa PVC

Dostępne są dwa warianty króćca rewizyjnego siodłowy i prosty.

W zakresie dostawy jest uszczelka EPDM.

1.37. Przejście ścienne

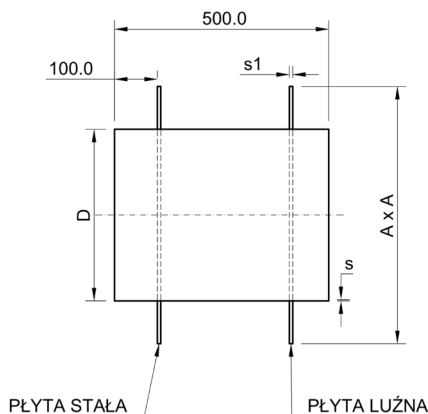
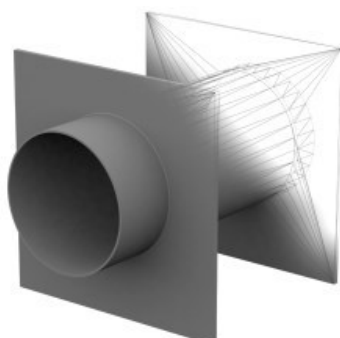

Oznaczenia w tabeli:

- a. **D** - średnica zewnętrzna rury
- b. **s1** - grubość płyty
- c. **s** - grubość ścianki
- d. **XX** - oznaczenie materiału

D	Nr kat.	A x A	s1	PVC	PPs	PP-EL-s	PP	PE
				s				
mm	---	mm	mm	mm				
110	XX.110.L.7001	210	6	1,8	3,0	3,0	2,7	3,4
125	XX.125.L.7001	275	6	1,8	3,0	3,0	3,1	3,9
140	XX.140.L.7001	290	6	1,8	3,0	3,0	3,5	4,3
160	XX.160.L.7001	310	6	1,8	3,0	3,0	4,0	4,0
180	XX.180.L.7001	330	6	1,8	3,0	3,0	4,4	5,5
200	XX.200.L.7001	350	8	1,8	3,0	3,0	3,0	6,2
225	XX.225.L.7001	425	8	1,8	3,5	3,5	5,5	6,9
250	XX.250.L.7001	450	8	2,0	3,5	3,5	3,5	6,2
280	XX.280.L.7001	480	8	2,3	3,5	3,5	6,9	8,6
315	XX.315.L.7001	515	8	2,5	5,0	5,0	5,0	7,7
355	XX.355.L.7001	555	8	2,9	5,0	5,0	5,0	10,9
400	XX.400.L.7001	600	8	3,2	6,0	6,0	6,0	12,3
450	XX.450.L.7001	750	10	3,6	6,0	6,0	6,0	6,0
500	XX.500.L.7001	800	10	4,0	6,0	6,0	6,0	6,0
560	XX.560.L.7001	860	10	-	6,0	6,0	6,0	6,0
600	XX.600.L.7001	900	10	5,0	6,0	6,0	6,0	6,0
630	XX.630.L.7001	930	10	-	6,0	6,0	6,0	6,0
700	XX.700.L.7001	1100	12	6,0	6,0	6,0	6,0	6,0
710	XX.710.L.7001	1100	12	-	6,0	6,0	6,0	6,0
800	XX.800.L.7001	1200	12	8,0	8,0	8,0	8,0	8,0
900	XX.900.L.7001	1300	12	8,0	8,0	8,0	8,0	8,0
1000	XX.1000.L.7001	1400	12	10,0	10,0	10,0	10,0	10,0
1200	XX.1200.L.7001	1600	12	12,0	12,0	12,0	12,0	12,0
1250	XX.1250.L.7001	1650	12	12,0	12,0	12,0	12,0	12,0

1.38. Złącze elastyczne 4 karbowe PVC i TPE, łączenie na opaski

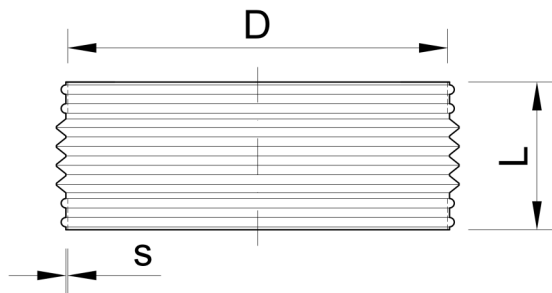
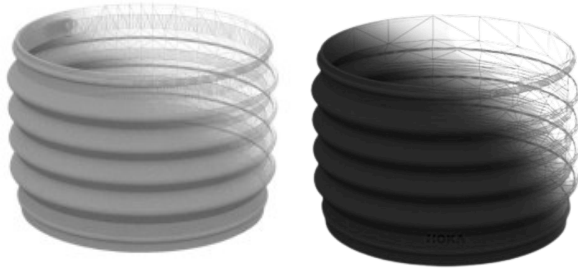

D	Nr kat.	L	PVC	TPE
			s	
mm	---	mm	mm	mm
75*	XX.075.E.0000	90	2,0	-
90*	XX.090.E.0000	90	2,0	-
110*	XX.110.E.0000	90	2,0	-
125*	XX.125.E.0000	90	2,0	-
140	XX.140.E.0000	150	2,0	-
160	XX.160.E.0000	150	2,0	2,5
180	XX.180.E.0000	150	2,0	2,5
200	XX.200.E.0000	150	2,0	2,5
225	XX.225.E.0000	150	2,0	2,5
250	XX.250.E.0000	150	2,0	2,5
280	XX.280.E.0000	150	2,0	2,5
315	XX.315.E.0000	150	2,0	2,5
355	XX.355.E.0000	150	2,0	2,5
400	XX.400.E.0000	150	2,0	2,5
450	XX.450.E.0000	150	2,0	2,5
500	XX.500.E.0000	150	2,0	2,5
560	XX.560.E.0000	150	2,0	2,5
600	XX.600.E.0000	150	2,0	2,5
630	XX.630.E.0000	150	2,0	2,5
700	XX.700.E.0000	150	2,0	2,5
710	XX.710.E.0000	150	2,0	2,5
800	XX.800.E.0000	150	2,0	2,5
900	XX.900.E.0000	150	2,0	2,5
1000	XX.1000.E.0000	150	2,0	2,5
1200	XX.1200.E.0000	150	2,0	2,5
1250	XX.1250.E.0000	150	2,0	2,5

Oznaczenia w tabeli:

- D - średnica zewnętrzna rury
- L - długość złącza
- s - grubość ścianki
- XX - oznaczenie materiału w systemie Chemowent

* złącza PVC d75, d90, d110 i d125 dostępne w wykonaniu 3 karbowym

1.39. Złącze elastyczne 4 karbowe PVC i TPE, łączenie na mufy

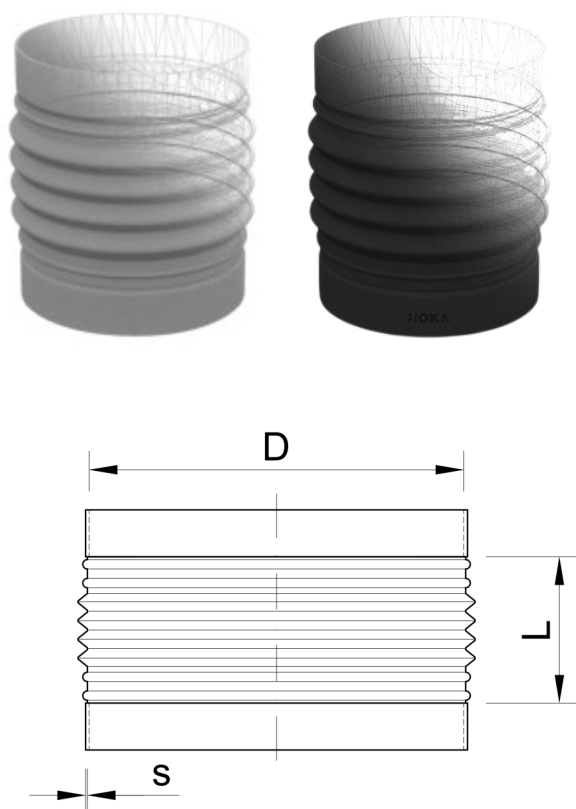

D	Nr kat.	L	PVC	TPE
			s	
mm	---	mm	mm	mm
75*	88.075.E.0001.YY	90	2,0	-
90*	88.090.E.0001.YY	90	2,0	-
110*	88.110.E.0001.YY	90	2,0	-
125*	88.125.E.0001.YY	90	2,0	-
140	88.140.E.0001.YY	150	2,0	-
160	XX.160.E.0001.YY	150	2,0	2,5
180	XX.180.E.0001.YY	150	2,0	2,5
200	XX.200.E.0001.YY	150	2,0	2,5
225	XX.225.E.0001.YY	150	2,0	2,5
250	XX.250.E.0001.YY	150	2,0	2,5
280	XX.280.E.0001.YY	150	2,0	2,5
315	XX.315.E.0001.YY	150	2,0	2,5
355	XX.355.E.0001.YY	150	2,0	2,5
400	XX.400.E.0001.YY	150	2,0	2,5
450	XX.450.E.0001.YY	150	2,0	2,5
500	XX.500.E.0001.YY	150	2,0	2,5
560	XX.560.E.0001.YY	150	2,0	2,5
600	XX.600.E.0001.YY	150	2,0	2,5
630	XX.630.E.0001.YY	150	2,0	2,5
700	XX.700.E.0001.YY	150	2,0	2,5
710	XX.710.E.0001.YY	150	2,0	2,5
800	XX.800.E.0001.YY	150	2,0	2,5
900	XX.900.E.0001.YY	150	2,0	2,5
1000	XX.1000.E.0001.YY	150	2,0	2,5
1200	XX.1200.E.0001.YY	150	2,0	2,5
1250	XX.1250.E.0001.YY	150	2,0	2,5

Oznaczenia w tabeli:

- a. **D** - średnica zewnętrzna rury
- b. **L** - długość złącza
- c. **s** - grubość ścianki
- d. **XX** - oznaczenie materiału w systemie Chemowent
- e. **YY** - oznaczenie materiału mufy (do złącz TPE nie można wykonać muf z PVC)

* złącza PVC d75, d90, d110 i d125 dostępne w wykonaniu 3 karbowym

1.40. Złącze elastyczne 4 karbowe PVC i TPE, łączenie na kołnierze

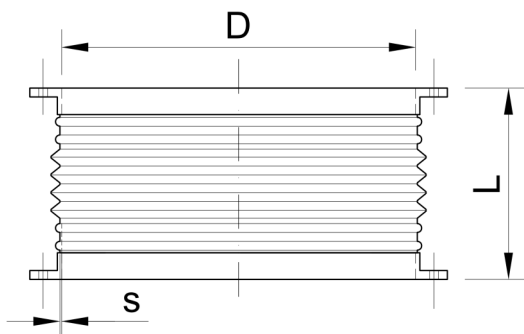
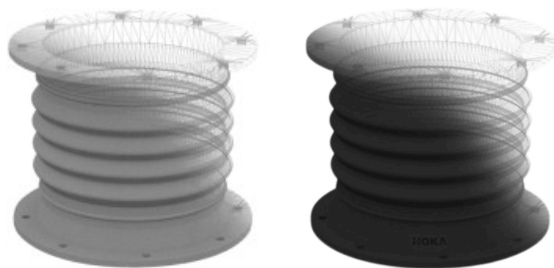

D	Nr kat.	L	PVC	TPE
			s	
mm	---	mm	mm	
75*	88.075.E.0003.YY	155	2,0	-
90*	88.090.E.0003.YY	155	2,0	-
110*	88.110.E.0003.YY	155	2,0	-
125*	88.125.E.0003.YY	155	2,0	-
140	88.140.E.0003.YY	215	2,0	-
160	XX.160.E.0003.YY	215	2,0	2,5
180	XX.180.E.0003.YY	215	2,0	2,5
200	XX.200.E.0003.YY	215	2,0	2,5
225	XX.225.E.0003.YY	215	2,0	2,5
250	XX.250.E.0003.YY	215	2,0	2,5
280	XX.280.E.0003.YY	215	2,0	2,5
315	XX.315.E.0003.YY	215	2,0	2,5
355	XX.355.E.0003.YY	215	2,0	2,5
400	XX.400.E.0003.YY	215	2,0	2,5
450	XX.450.E.0003.YY	180	2,0	2,5
500	XX.500.E.0003.YY	180	2,0	2,5
560	XX.560.E.0003.YY	180	2,0	2,5
600	XX.600.E.0003.YY	180	2,0	2,5
630	XX.630.E.0003.YY	180	2,0	2,5
700	XX.700.E.0003.YY	180	2,0	2,5
710	XX.710.E.0003.YY	180	2,0	2,5
800	XX.800.E.0003.YY	180	2,0	2,5
900	XX.900.E.0003.YY	180	2,0	2,5
1000	XX.1000.E.0003.YY	180	2,0	2,5
1200	XX.1200.E.0003.YY	180	2,0	2,5
1250	XX.1250.E.0003.YY	180	2,0	2,5

Oznaczenia w tabeli:

- a. **D** - średnica zewnętrzna rury
- b. **L** - długość złącza
- c. **s** - grubość ścianki
- d. **XX** - oznaczenie materiału w systemie Chemowent
- e. **YY** - oznaczenie materiału kołnierza (do złączy TPE nie można wykonać kołnierzy z PVC)

* złącza PVC d75, d90, d110 i d125 dostępne w wykonaniu 3 karbowym

1.41. Złącze elastyczne 6 karbowe TPE, łączenie na opaski

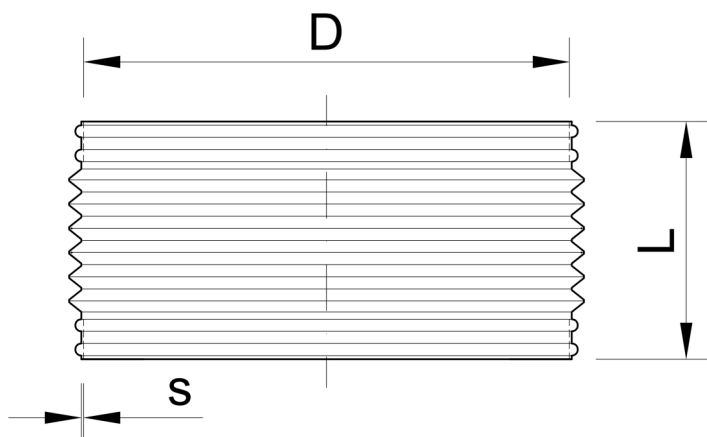
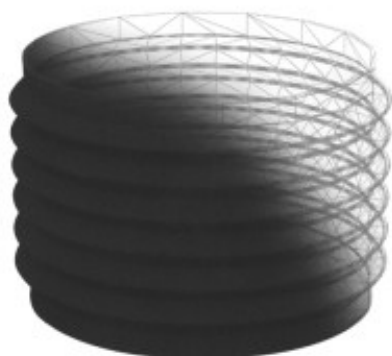

D	Nr kat.	L	s
mm	---	mm	mm
160	11.160.E.0600	150	2,5
180	11.180.E.0600	150	2,5
200	11.200.E.0600	150	2,5
225	11.225.E.0600	150	2,5
250	11.250.E.0600	150	2,5
280	11.280.E.0600	150	2,5
315	11.315.E.0600	150	2,5
355	11.355.E.0600	150	2,5
400	11.400.E.0600	150	2,5
450	11.450.E.0600	150	2,5
500	11.500.E.0600	150	2,5
560	11.560.E.0600	150	2,5
600	11.600.E.0600	150	2,5
630	11.630.E.0600	150	2,5
700	11.700.E.0600	150	2,5
710	11.710.E.0600	150	2,5
800	11.800.E.0600	150	2,5
900	11.900.E.0600	150	2,5
1000	11.1000.E.0600	150	2,5
1200	11.1200.E.0600	150	2,5
1250	11.1250.E.0600	150	2,5

Oznaczenia w tabeli:

- a. **D** - średnica zewnętrzna rury
- b. **L** - długość złącza
- c. **s** - grubość ścianki

1.42. Złącze elastyczne 6 karbowe TPE, łączenie na mufy

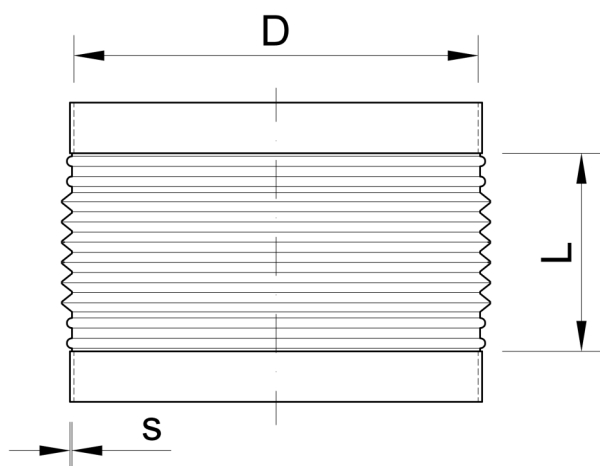

D	Nr kat.	L	s
mm	---	mm	mm
160	11.160.E.0601.YY	185	2,5
180	11.180.E.0601.YY	195	2,5
200	11.200.E.0601.YY	185	2,5
225	11.225.E.0601.YY	195	2,5
250	11.250.E.0601.YY	185	2,5
280	11.280.E.0601.YY	195	2,5
315	11.315.E.0601.YY	195	2,5
355	11.355.E.0601.YY	195	2,5
400	11.400.E.0601.YY	195	2,5
450	11.450.E.0601.YY	195	2,5
500	11.500.E.0601.YY	195	2,5
560	11.560.E.0601.YY	195	2,5
600	11.600.E.0601.YY	195	2,5
630	11.630.E.0601.YY	195	2,5
700	11.700.E.0601.YY	195	2,5
710	11.710.E.0601.YY	195	2,5
800	11.800.E.0601.YY	195	2,5
900	11.900.E.0601.YY	195	2,5
1000	11.1000.E.0601.YY	195	2,5
1200	11.1200.E.0601.YY	195	2,5
1250	11.1250.E.0601.YY	195	2,5

Oznaczenia w tabeli:

- a. **D** - średnica zewnętrzna rury
- b. **L** - długość złącza
- c. **s** - grubość ścianki
- e. **YY** - oznaczenie materiału mufy (do złączy TPE nie można wykonać muf z PVC)

1.43. Złącze elastyczne 6 karbowe TPE, łączenie na kołnierze

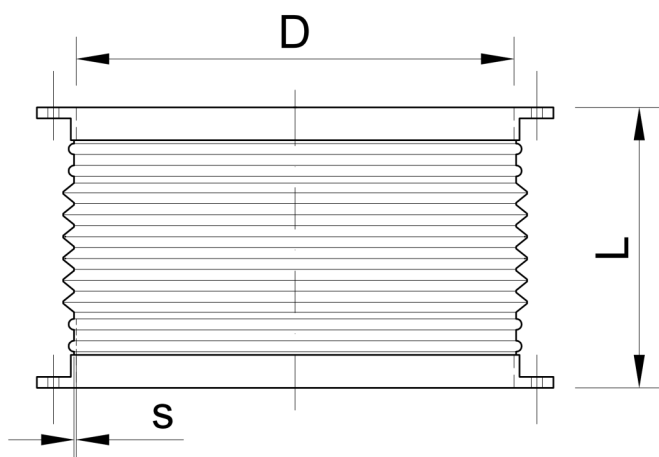

D	Nr kat.	L	s
mm	---	mm	mm
160	11.160.E.0603.YY	220	2,5
180	11.180.E.0603.YY	220	2,5
200	11.200.E.0603.YY	220	2,5
225	11.225.E.0603.YY	220	2,5
250	11.250.E.0603.YY	220	2,5
280	11.280.E.0603.YY	220	2,5
315	11.315.E.0603.YY	220	2,5
355	11.355.E.0603.YY	220	2,5
400	11.400.E.0603.YY	220	2,5
450	11.450.E.0603.YY	185	2,5
500	11.500.E.0603.YY	185	2,5
560	11.560.E.0603.YY	185	2,5
600	11.600.E.0603.YY	185	2,5
630	11.630.E.0603.YY	185	2,5
700	11.700.E.0603.YY	185	2,5
710	11.710.E.0603.YY	185	2,5
800	11.800.E.0603.YY	185	2,5
900	11.900.E.0603.YY	185	2,5
1000	11.1000.E.0603.YY	185	2,5
1200	11.1200.E.0603.YY	185	2,5
1250	11.1250.E.0603.YY	185	2,5

Oznaczenia w tabeli:

- a. **D** - średnica zewnętrzna rury
- b. **L** - długość złącza
- c. **s** - grubość ścianki
- d. **YY** - oznaczenie materiału kołnierza (do złączy TPE nie można wykonać kołnierzy z PVC)

1.44. Kratka

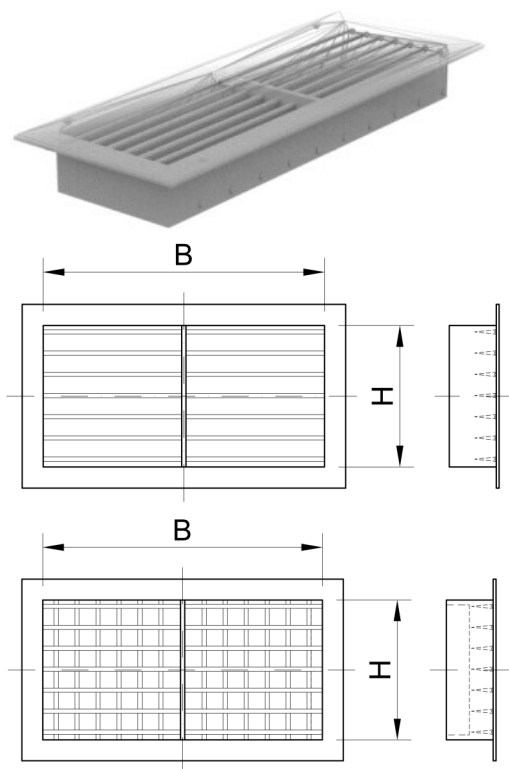

B	H	Nr kat.
mm	mm	---
300	100	88.300.Y.0100
400	100	88.400.Y.0100
500	100	88.500.Y.0100
600	100	88.600.Y.0100
300	150	88.300.Y.0150
400	150	88.400.Y.0150
500	150	88.500.Y.0150
600	150	88.600.Y.0150
300	200	88.300.Y.0200
400	200	88.400.Y.0200
500	200	88.500.Y.0200
600	200	88.600.Y.0200
300	250	88.300.Y.0250
400	250	88.400.Y.0250
500	250	88.500.Y.0250
600	250	88.600.Y.0250

Oznaczenia w tabeli:

a. **Y** - wybór typu kratki : **A** - lamele poziome (typ LG-A); **C** - lamele poziome i pionowe (typ LG-C)

Kratki wykonane są z szarego PVC.

Możemy wykonać również kratki z lamelami nieruchomymi.

1.45. Ramka montażowa do kratki

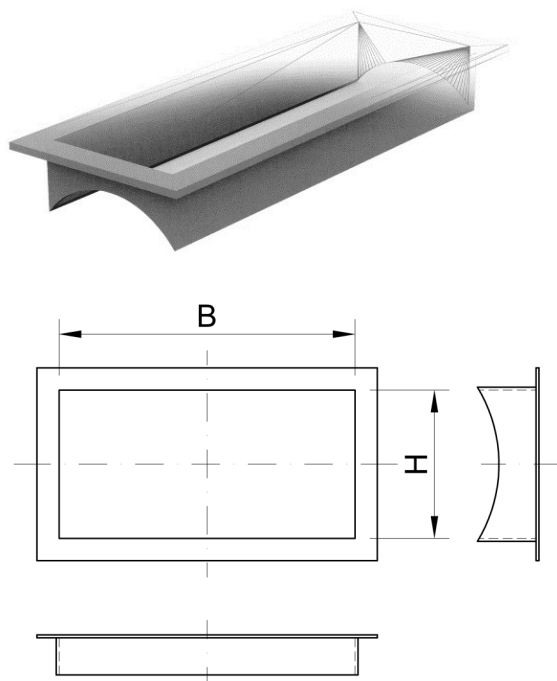

B	H	Nr kat.
mm	mm	---
300	100	XX.3010.D.Y
400	100	XX.4010.D.Y
500	100	XX.5010.D.Y
600	100	XX.6010.D.Y
300	150	XX.3015.D.Y
400	150	XX.4015.D.Y
500	150	XX.5015.D.Y
600	150	XX.6015.D.Y
300	200	XX.3020.D.Y
400	200	XX.4020.D.Y
500	200	XX.5020.D.Y
600	200	XX.6020.D.Y
300	250	XX.3025.D.Y
400	250	XX.4025.D.Y
500	250	XX.5025.D.Y
600	250	XX.6025.D.Y

Oznaczenia w tabeli:

- a. **Y** - średnica kanału, na którym montowana ma być kratka (mm)
- b. **XX** - oznaczenie materiału w systemie Chemowent

Wymiary H i B są powiększone o 5 mm, aby umożliwić swobodny montaż kratki

1.46. Króciec siodłowy 90°

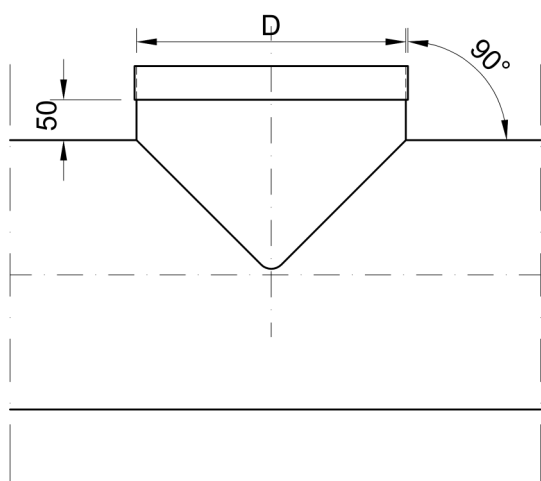
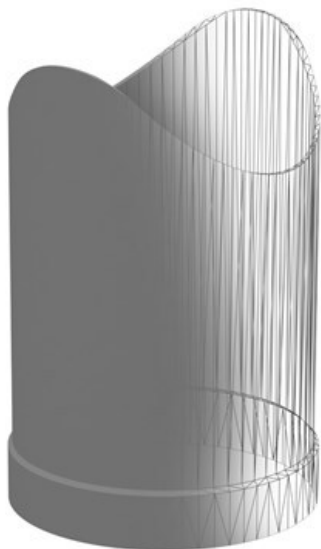

D	Nr kat.
mm	---
50	XX.050.O.90Y
63	XX.063.O.90Y
75	XX.075.O.90Y
90	XX.090.O.90Y
110	XX.110.O.90Y
125	XX.125.O.90Y
140	XX.140.O.90Y
160	XX.160.O.90Y
180	XX.180.O.90Y
200	XX.200.O.90Y
225	XX.225.O.90Y
250	XX.250.O.90Y
280	XX.280.O.90Y
315	XX.315.O.90Y
355	XX.355.O.90Y
400	XX.400.O.90Y
450	XX.450.O.90Y
500	XX.500.O.90Y
560*	XX.560.O.90Y
600	XX.600.O.90Y
630*	XX.630.O.90Y
700	XX.700.O.90Y
710*	XX.710.O.90Y
800	XX.800.O.90Y
900	XX.900.O.90Y
1000	XX.1000.O.90Y
1200	XX.1200.O.90Y
1250	XX.1250.O.90Y

Oznaczenia w tabeli:

- D** - średnica zewnętrzna rury
- Y** - średnica kanału, na którym montowany będzie króciec
- XX** - oznaczenie materiału w systemie Chemowent

* w tych średnicach nie są produkowane króćce siodłowe z tworzywa PVC

1.47. Króciec siodłowy 45°

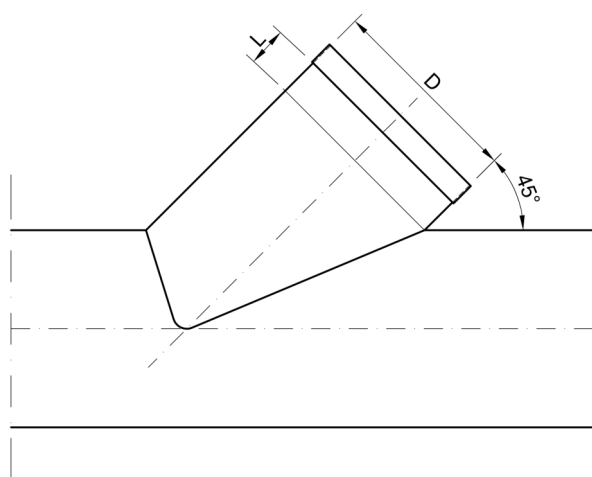
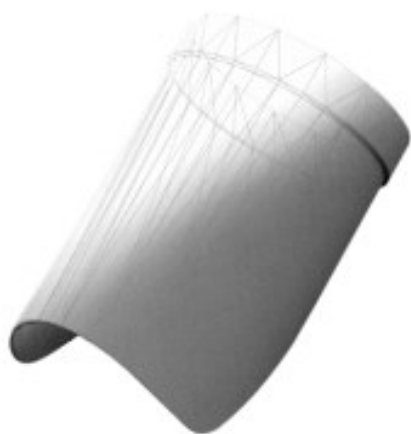

D	Nr kat.	L
mm	---	mm
50	XX.050.O.45Y	25
63	XX.063.O.45Y	25
75	XX.075.O.45Y	40
90	XX.090.O.45Y	40
110	XX.110.O.45Y	40
125	XX.125.O.45Y	40
140	XX.140.O.45Y	40
160	XX.160.O.45Y	40
180	XX.180.O.45Y	40
200	XX.200.O.45Y	40
225	XX.225.O.45Y	40
250	XX.250.O.45Y	40
280	XX.280.O.45Y	50
315	XX.315.O.45Y	50
355	XX.355.O.45Y	50
400	XX.400.O.45Y	50
450	XX.450.O.45Y	50
500	XX.500.O.45Y	50
560*	XX.560.O.45Y	60
600	XX.600.O.45Y	60
630*	XX.630.O.45Y	70
700	XX.700.O.45Y	70
710*	XX.710.O.45Y	80
800	XX.800.O.45Y	80
900	XX.900.O.45Y	90
1000	XX.1000.O.45Y	100
1200	XX.1200.O.45Y	120
1250	XX.1250.O.45Y	130

Oznaczenia w tabeli:

- a. **D** - średnica zewnętrzna rury
- b. **Y** - średnica kanału, na którym montowany będzie króciec
- c. **XX** - oznaczenie materiału w systemie Chemowent

* w tych średnicach nie są produkowane króćce siodłowe z tworzywa PVC

1.48. Tłumik okrągły

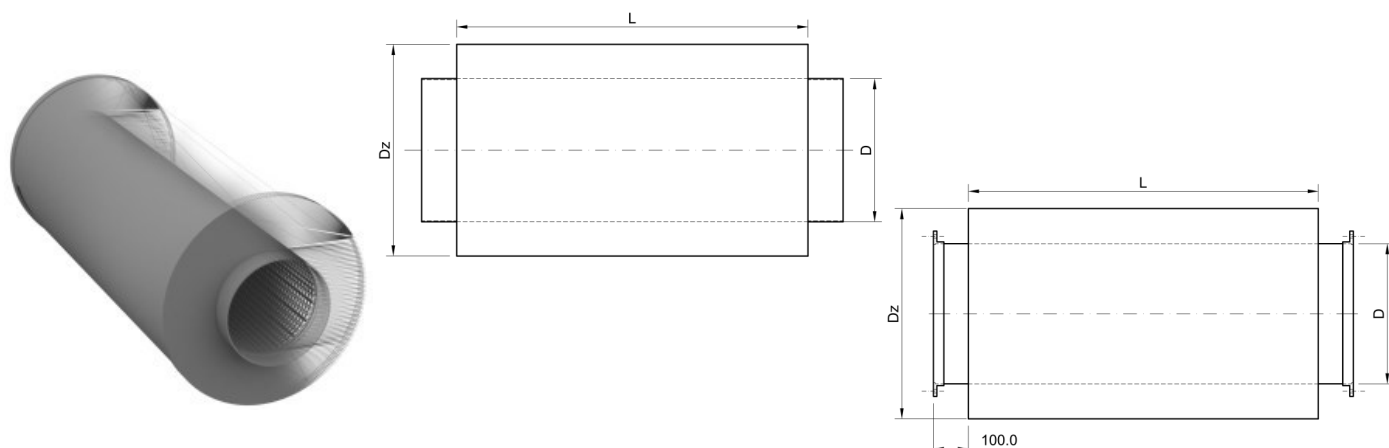

D	Nr kat.	L (mm)						
		500	750	1000	1250	1500	1750	2000
mm	---	Dz						
		mm						
75	XX.075.Y.L	315	315	315	315	315	315	315
90	XX.090.Y.L	315	315	315	315	315	315	315
110	XX.110.Y.L	315	315	315	315	315	315	315
125	XX.125.Y.L	315	315	315	315	315	315	315
140	XX.140.Y.L	355	355	355	355	355	355	355
160	XX.160.Y.L	355	355	355	355	355	355	355
180	XX.180.Y.L	400	400	400	400	400	400	400
200	XX.200.Y.L	400	400	400	400	400	400	400
225	XX.225.Y.L	450	450	450	450	450	450	450
250	XX.250.Y.L	450	450	450	450	450	450	450
280	XX.280.Y.L	500	500	500	500	500	500	500
315	XX.315.Y.L	500	500	500	500	500	500	500
355	XX.355.Y.L	500	500	500	500	500	500	500
400	XX.400.Y.L	600	600	600	600	600	600	600
450	XX.450.Y.L	-	-	700	700	700	700	700
500	XX.500.Y.L	-	-	700	700	700	700	700
560	XX.560.Y.L	-	-	800	800	800	800	800
600	XX.600.Y.L	-	-	800	800	800	800	800
630	XX.630.Y.L	-	-	800	800	800	800	800
700	XX.700.Y.L	-	-	900	900	900	900	900
710	XX.710.Y.L	-	-	900	900	900	900	900
800	XX.800.Y.L	-	-	1000	1000	1000	1000	1000
900	XX.900.Y.L	-	-	1100	1100	1100	1100	1100
1000	XX.1000.Y.L	-	-	1200	1200	1200	1200	1200
1200	XX.1200.Y.L	-	-	1400	1400	1400	1400	1400
1250	XX.1250.Y.L	-	-	1400	1400	1400	1400	1400

Oznaczenia w tabeli:

- a. **D** - średnica zewnętrzna rury
- b. **L** - długość warstwy tłumiącej
- c. **Y** - wybór wariantu: **M** - mufowy; **K** - kołnierzowy; **B** - bosy
- d. **Dz** - Średnica zewnętrzna warstwy tłumiącej
- e. **XX** - oznaczenie materiału w systemie Chemowent

Strata ciśnienia dla tłumików na 1 mb kulisy tłumiącej

Prędkość przepływu	Strata ciśnienia
m/s	Pa/mb
5 - 8	20 - 25
8 - 12	25 - 35
12 - 15	35 - 45

Charakterystyka akustyczna tłumików okrągłych

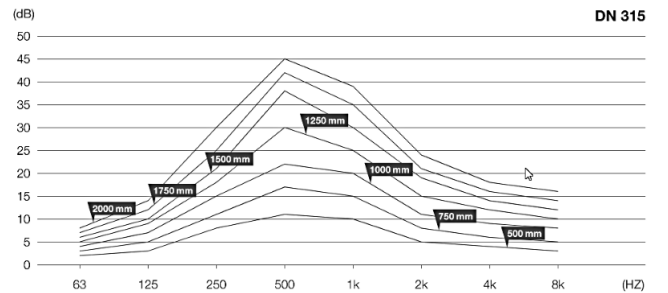
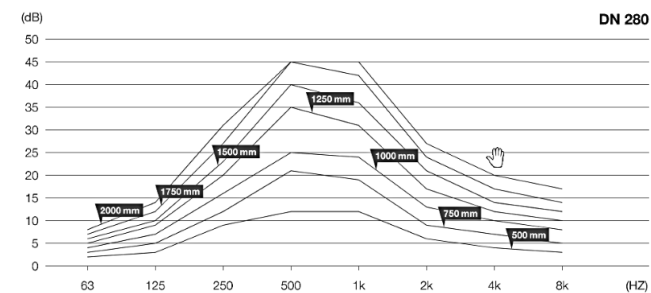
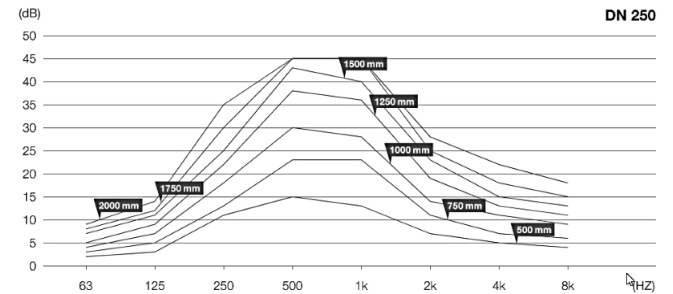
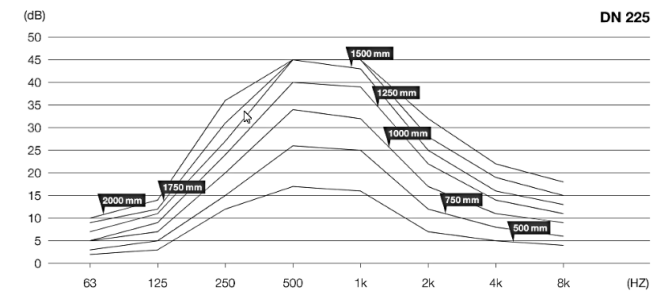
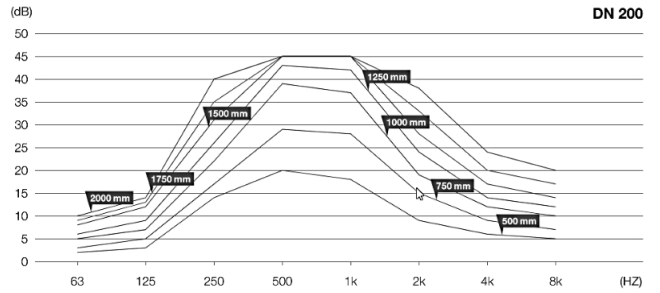
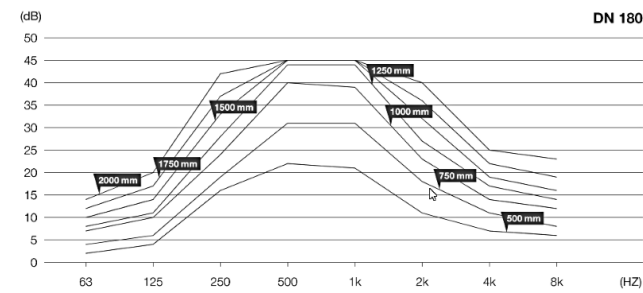
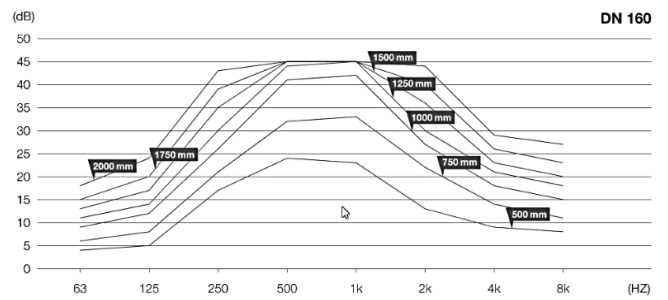
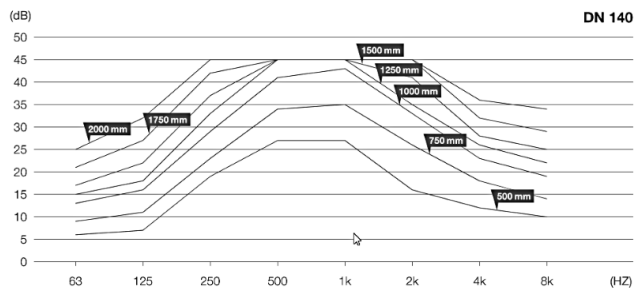
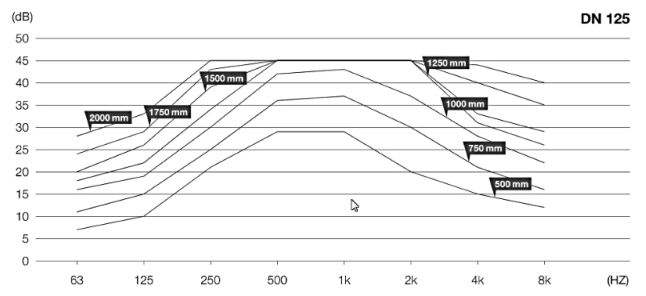
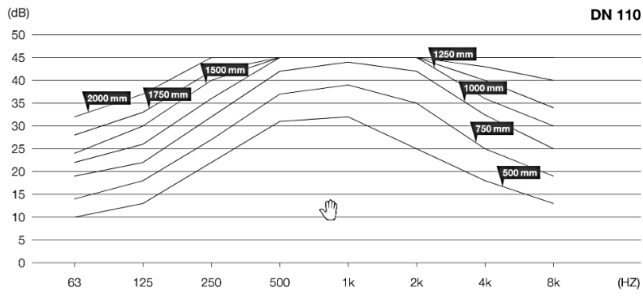

Charakterystyka akustyczna tłumików okrągłych

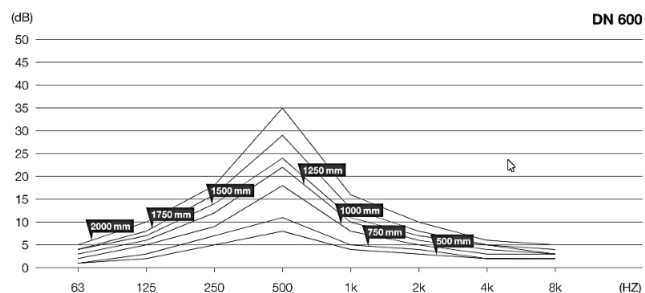
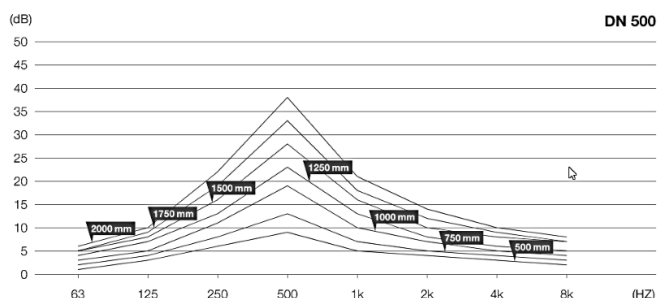
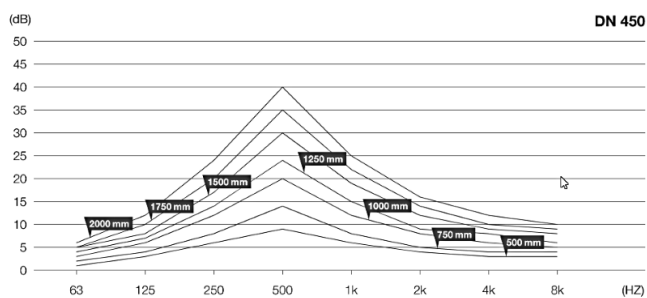
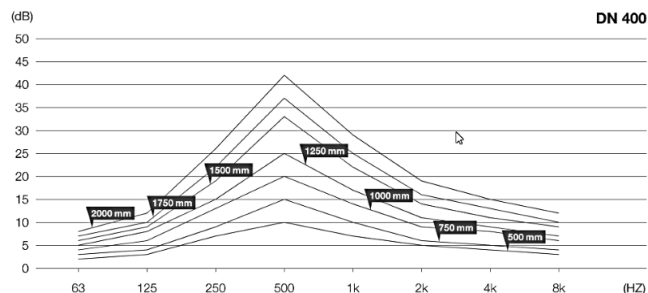
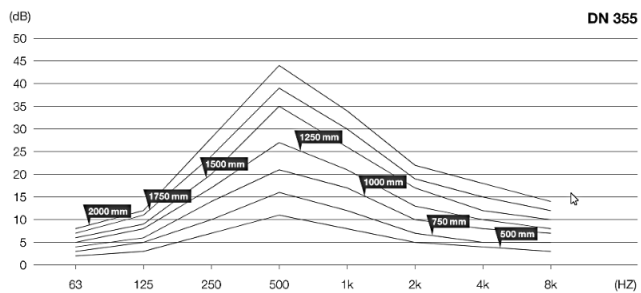

Kanały i kształtki prostokątne



Wymiary i oznaczenia kanałów i kształtek

Wielkość nominalna kanałów to zewnętrzne wymiary boków a i b (gdzie b jest bokiem widocznym). Dla kształtek przejściowych stosuje się oznaczenia c i d. Na życzenie klienta możliwe są wykonania niestandardowe.

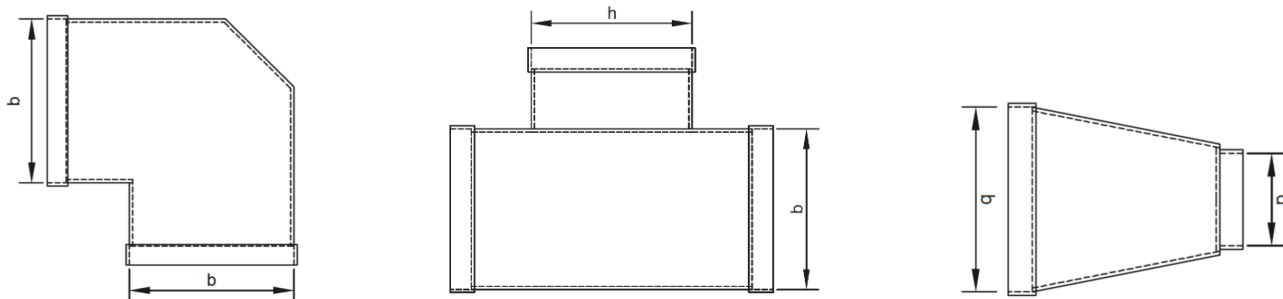

Metody łączenia kanałów i kształtek

Najczęściej stosowanym rozwiązaniem jest spawanie – zapewniające wysoką szczelność. Alternatywnie, oferujemy łączenia kołnierzowe z zastosowaniem uszczelki EPDM i śrub. Ten typ połączeń ułatwia montaż w ograniczonych przestrzeniach oraz późniejszy serwis lub demontaż.

Sztywność i stabilność elementów wentylacyjnych

Sztywność kanałów osiągana jest poprzez dobór odpowiedniej grubości materiału. Przy większych przekrojach stosujemy ożebrowania. Kanały mogą być dodatkowo wzmacniane kierownicami zgodnie z PN-EN 1505. Kolana o kącie $\leq 45^\circ$ nie wymagają dodatkowych kierownic.

Grubości ścianek – dobór tworzywa i normy

Stosujemy tworzywa: PVC, PP, PPs, PP-EL-s i PE – dobierane pod kątem odporności chemicznej i warunków pracy. Grubości płyt wyznaczone są zgodnie z normą zakładową oraz normami DIN 4740 i 4741. Możliwy jest też indywidualny dobór.

Długość boku, mm	200	250	300	400	500	600	800	1000	1200
200	4	4	4	4	6	6	8	10	12
250	4	4	4	4	6	6	8	10	12
300	4	4	4	4	6	6	8	10	12
400	4	4	4	4	6	6	8	10	12
500	6	6	6	6	6	6	8	10	12
600	6	6	6	6	6	6	8	10	12
800	8	8	8	8	8	8	8	10	12
1000	10	10	10	10	10	10	10	10	12
1200	12	12	12	12	12	12	12	12	12

Materiały do produkcji

- **PVC** – kolor ciemny szary - oznaczenie w systemie **88**
- **PPs** – kolor szary - oznaczenie w systemie **36**
- **PP-EL-s** – kolor czarny - oznaczenie w systemie **40**
- **PP** – kolor jasny szary - oznaczenie w systemie **30**
- **PE** – kolor czarny - oznaczenie w systemie **22**

2.1 Kanał prostokątny

Długości standardowe:

1000, 1500, 2000, 3000 mm (2 × 1,5 m) .

Zakończenia: bosc (standard)

Warianty zakończeń:

- M – mufa
- K – kołnierz

Grubość ścianek i ewentualne uźebrowanie - zależne od parametrów medium

Szerokość mufy - 60 mm

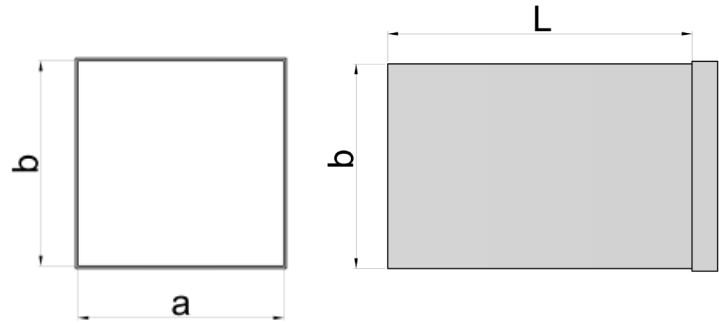
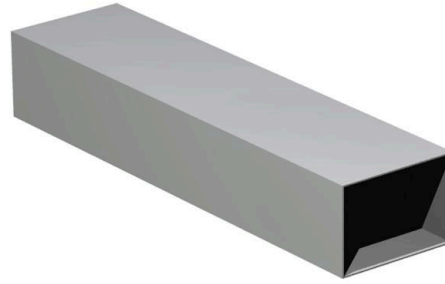

Przykładowe oznaczenie kanału

88	K	500	300	2000
Materiał: 88,40,36,30,22	Typ	Bok a , mm	Bok b , mm	Długość L , mm

2.2 Kolano / łuk prostokątny

Kąty standardowe:

15°, 30°, 45°, 60°, 75°, 90°

Odsadzenie - 150 mm

Warianty zakończeń:

- M – mufa
- K – kołnierz
- B – bosc

Szerokość mufy - 60 mm

Zastosowanie:

Kolana – dla instalacji o mniejszych prędkościach / ciśnieniach, przy $b < 400$ mm

Łuki segmentowe – dla instalacji o większych prędkościach / ciśnieniach, przy $b > 400$ mm

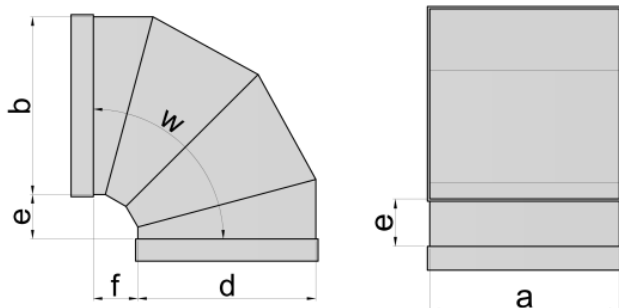
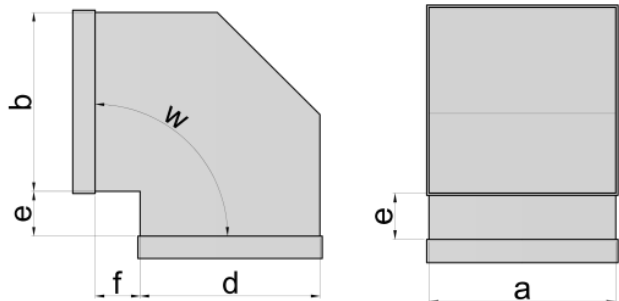

Przykładowe oznaczenie kolana/łuku

88	KP/ LP	500	300	500	90
Materiał: 88,40,36,30,22	Typ	Bok a , mm	Bok b , mm	Bok d , mm	Kąt w , (°)

2.3 Trójnik prostokątny

Kąt odejścia:

90° / 45°

Warianty wykonania:

- równoprzelotowy
- redukcyjny

Warianty zakończeń:

- M – mufa
 - K – kołnierz
 - B – bosa w
- n - standardowo 150 mm
Szerokość mufy - 60 mm

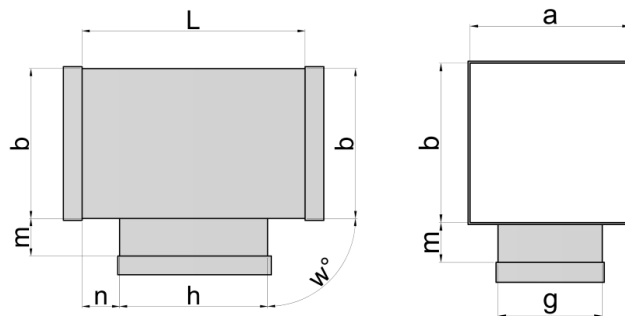
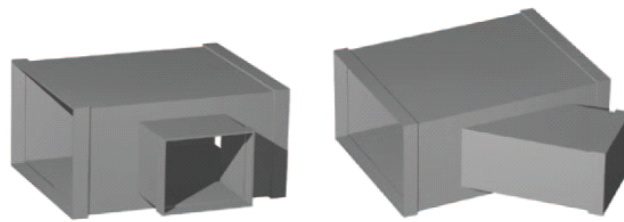

Przykładowe oznaczenie trójnika

88	TR	500	300	200	250	90
Materiał: 88,40,36,30,22	Typ	Bok a, mm	Bok b, mm	Bok odejścia g, mm	Bok odejścia h, mm	Kąt w, (°)

2.4 Redukcja symetryczna

Warianty zakończeń:

- M – mufa
- K – kołnierz
- B – bosa

Długość:

Min. długość L = długość krótszego boku.

Szerokość mufy - 60 mm

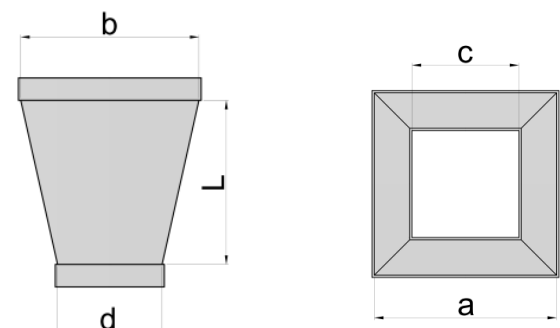
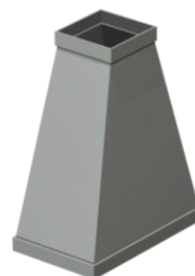

Przykładowe oznaczenie redukcji symetrycznej

88	RSPP	500	300	200	250	400
Materiał: 88,40,36,30,22	Typ	Bok a, mm	Bok b, mm	Bok c, mm	Bok d, mm	Długość L, mm

2.5 Redukcja asymetryczna

Warianty zakończeń:

- M – mufa
- K – kołnierz
- B – bosc

Długość:

Min. długość L = długość krótszego boku.

Szerokość mufy - 60 mm

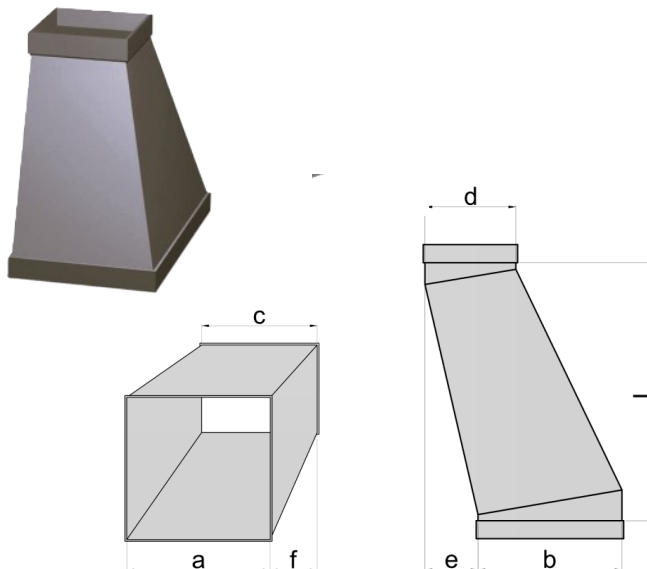

Przykładowe oznaczenie redukcji asymetrycznej

88	RAPP	500	300	200	250	50	400
Materiał: 88,40,36,30,22	Typ	Bok a, mm	Bok b, mm	Bok odejścia c, mm	Odsadzenie e, mm	Odsadzenie f, mm	Długość L, mm

2.6 Redukcja/przejście kwadrat - koło

Warianty zakończeń:

- M – mufa
- K – kołnierz
- B – bosc

Długość:

Min. długość L = długość krótszego boku.

Szerokość mufy - 60 mm

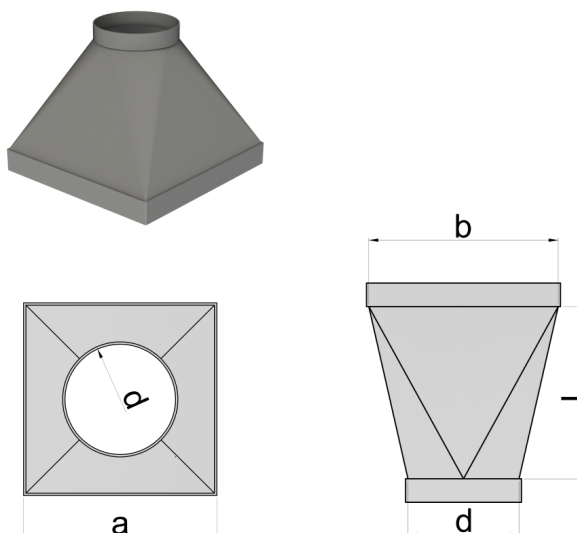

Przykładowe oznaczenie przejścia kwadrat - koło

88	RSPO	500	300	200	400
Materiał: 88,40,36,30,22	Typ	Bok a, mm	Bok b, mm	Średnica $\varnothing d$, mm	Długość L, mm

2.7 Odsadzka prostokątna

Warianty zakończeń:

- M – mufa
- K – kołnierz
- B – bosc

Szerokość mufy - 60 mm

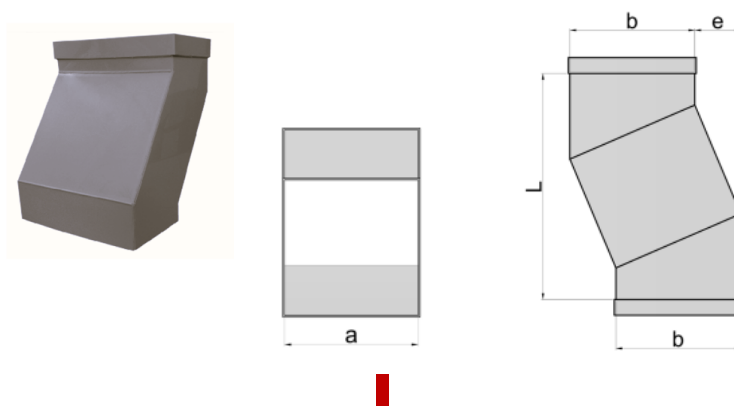

Przykładowe oznaczenie odsadzki

88	OD	500	300	50	600
Materiał: 88,40,36,30,22	Typ	Bok a , mm	Bok b , mm	Odsadzenie e , mm	Długość L , mm

2.8 Przepustnica prostokątna

Warianty:

- jednopłaszczyznowa
- wielopłaszczyznowa

Warianty zakończeń:

- M – mufa
- K – kołnierz
- B – bosc

Sterowanie:

- ręczne (standard)
- opcja: napęd elektryczny lub pneumatyczny

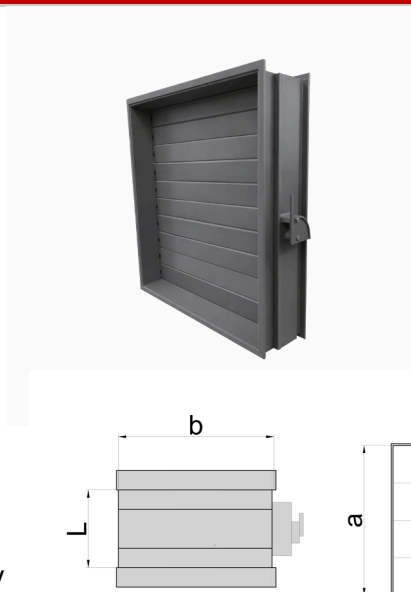

Przykładowe oznaczenie przepustnicy

88	PW	500	300	250	R
Materiał: 88,40,36,30,22	Typ	Bok a , mm	Bok b , mm	Odsadzenie e , mm	Sterowanie - ręczne R , elektryczne E , pneumatyczne P

2.9 Czerpnia ścienna

Warianty zakończeń:

- M – mufa
- K – kołnierz
- B – bosc



Długość $L \geq 100$ mm
Szerokość mufy - 60 mm

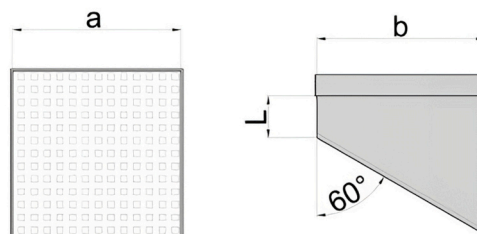

Przykładowe oznaczenie czerpni ściennej

88	CP	500	300	200
Materiał: 88,40,36,30,22	Typ	Bok a, mm	Bok b, mm	Długość L, mm

2.10 Czerpnia / wyrzutnia dachowa

Warianty zakończeń:

- M – mufa
- K – kołnierz
- B – bosc

Warianty wykonania:

- żaluzje skośne
- płyta perforowana

Warianty zabudowy:

- z dwóch stron
- z czterech stron

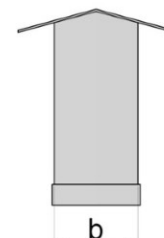
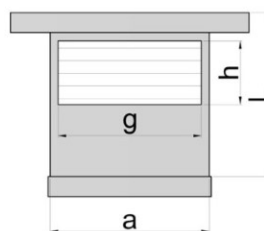

Długość $L \geq 100$ mm

Przykładowe oznaczenie czerpni dachowej

88	WD	500	300	300	250	800
Materiał: 88,40,36,30,22	Typ	Bok a, mm	Bok b, mm	Szerokość g, mm	Wysokość h, mm	Długość L, mm

2.11 Podstawa dachowa

Zastosowanie:

- wyprowadzenie instalacji na dach
- montaż czerpni i wyrzutni dachowych



Wariant zakończenia:

- B – bosc

Opcje wykonania:

- z okapnikiem – montaż na cokole
- bez okapnika – montaż na połąci

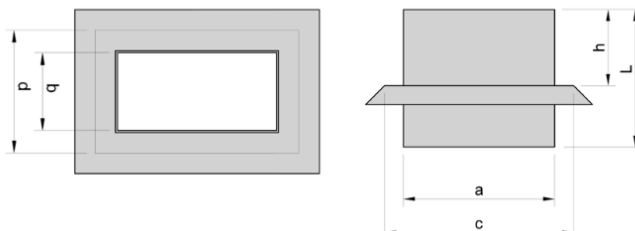

Przykładowe oznaczenie podstawy dachowej

88	PD	500	300	700	500	600
Materiał: 88,40,36,30,22	Typ	Bok a, mm	Bok b, mm	Płyta montażowa c, mm	Płyta montażowa d, mm	Długość L, mm

2.12 Kratka

Warianty wykonania:

- żaluzje skośne (stałe)
- płyta perforowana

Opcje (tylko dla PVC):

- lamele regulowane poziome (LG-A)
- lamele regulowane poziome oraz pionowe (LG-C)

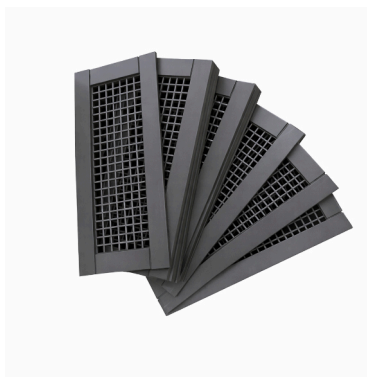

Montaż:

- bezpośrednio w kanale (otwór w kanale)
- na kanale z wykorzystaniem trójnika

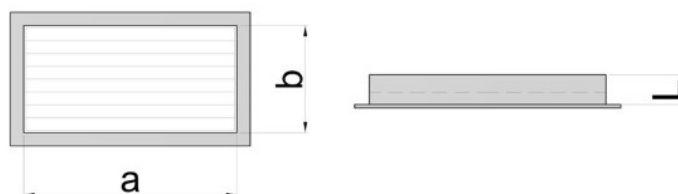

Przykładowe oznaczenie kratki

88	KW	500	300
Materiał: 88,40,36,30,22	Typ	Bok a, mm	Bok b, mm

2.13 Tłumik prostokątny

Warianty zakończeń:

- M – mufa
- K – kołnierz
- B – bosc

Szerokość kulis:

- 50 / 100 mm

Materiał wypełnienia:

- tkanina powlekana włóknem szklanym
- klasa palności A1

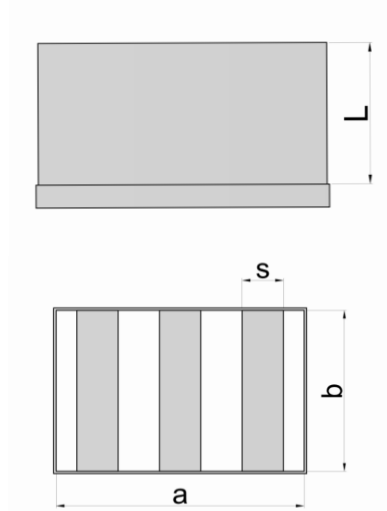

Przykładowe oznaczenie tłumika

88	TA	500	300	100	300
Materiał: 88,40,36,30,22	Typ	Bok a, mm	Bok b, mm	Kulisa s, mm	Długość L, mm

2.14 Okap

Króciec wyciągowy - zakończenie:

- M – mufa
- K – kołnierz
- B – bosc

Warianty:

- wiszący
- przyścienny

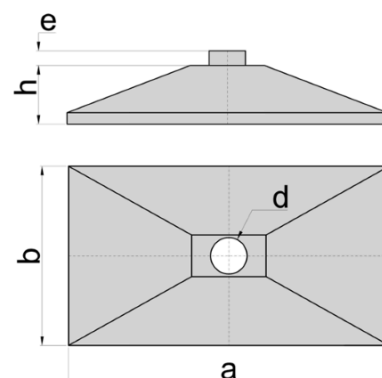

Przykładowe oznaczenie okapu

88	OP	500	300	200	500
Materiał: 88,40,36,30,22	Typ	Bok a, mm	Bok b, mm	Średnica \varnothing d, mm	Wysokość h, mm

Producent systemu CHEMOWENT

Grupa Konsultingowo-Inżynierska KOMPLEKS S.A.

ul. Ogrodowa 19

58-306 Wałbrzych

tel. 510 176 220 , 74 841 55 19

www.chemowent.pl

info@chemowent.pl



Firma Komplex ciągle rozwija i doskonali swoje produkty, stąd zastrzega sobie prawo do modyfikacji lub zmiany specyfikacji swoich wyrobów bez powiadamiania.

Wszystkie informacje zawarte w tej publikacji przygotowane zostały w dobrej wierze i w przeświadczeniu, że na dzień przekazania materiałów do dyspozycji są one aktualne i nie budzą zastrzeżeń. Niniejszy katalog nie stanowi oferty w rozumieniu przepisów Kodeksu Cywilnego, lecz informację o produktach.